



دانشگاه سیستان و بلوچستان
دانشکده مهندسی مکانیک

نقشه کشی صنعتی (۱) (Technical Drawing 1)

استاد درس:

دکتر عبدالواحد کمی



برش (Sectional view)

نمای برش خورده برای فهم راحت‌تر، نمایش اجزای داخلی و حذف خطوط ندید از نماها مورد استفاده قرار می‌گیرد.

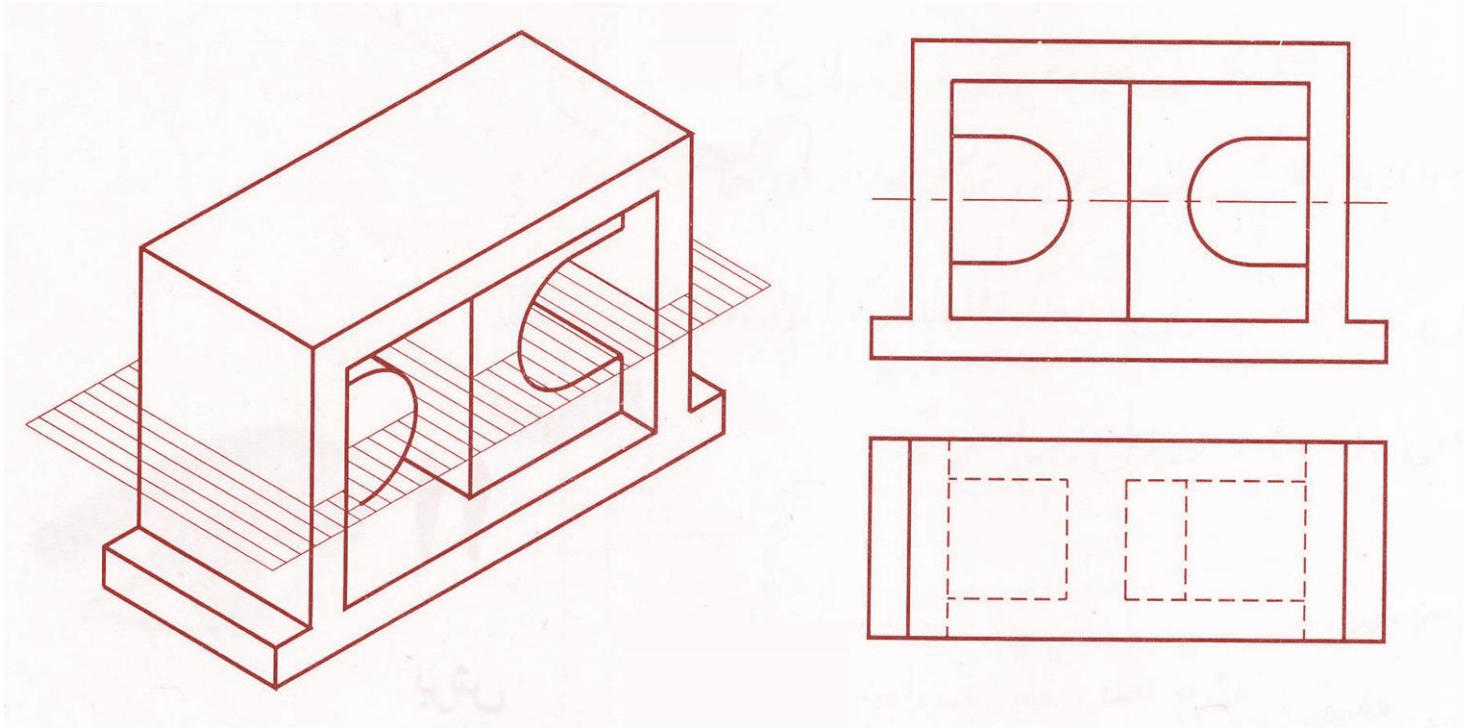



برش (Sectional view)

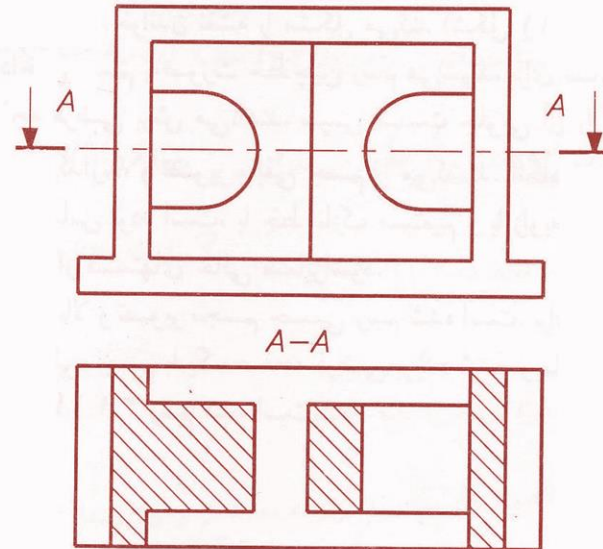
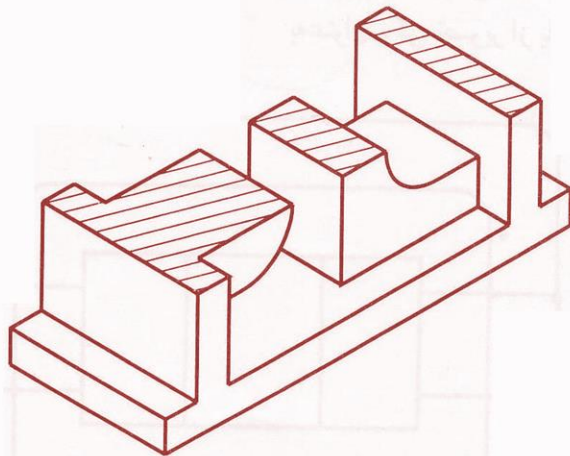
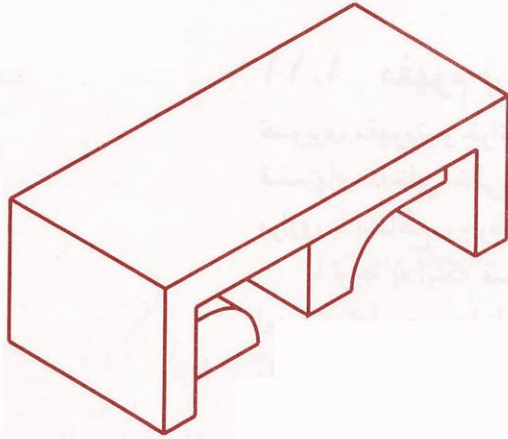



برش ساده

صفحه برش به موازات یکی از صفحات تصویر می‌باشد.

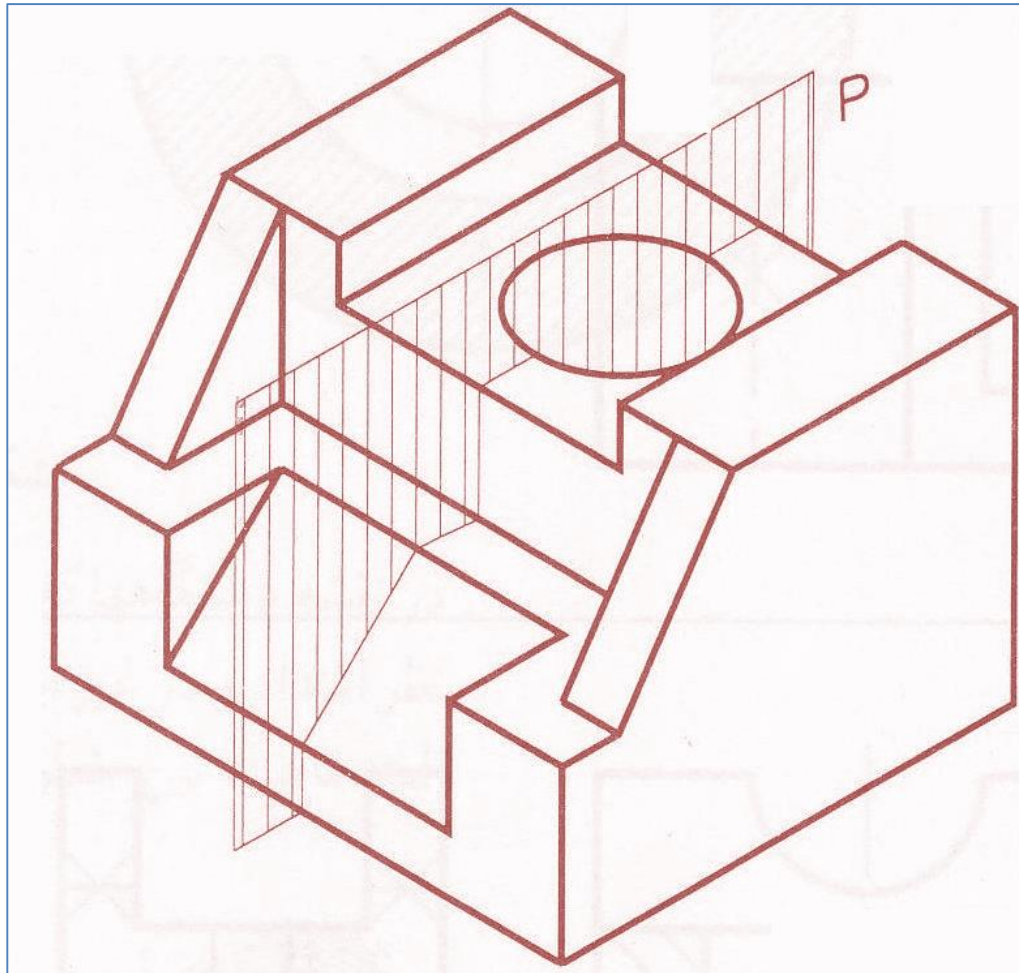

برش ساده

صفحه برش به موازات یکی از صفحات تصویر می باشد.

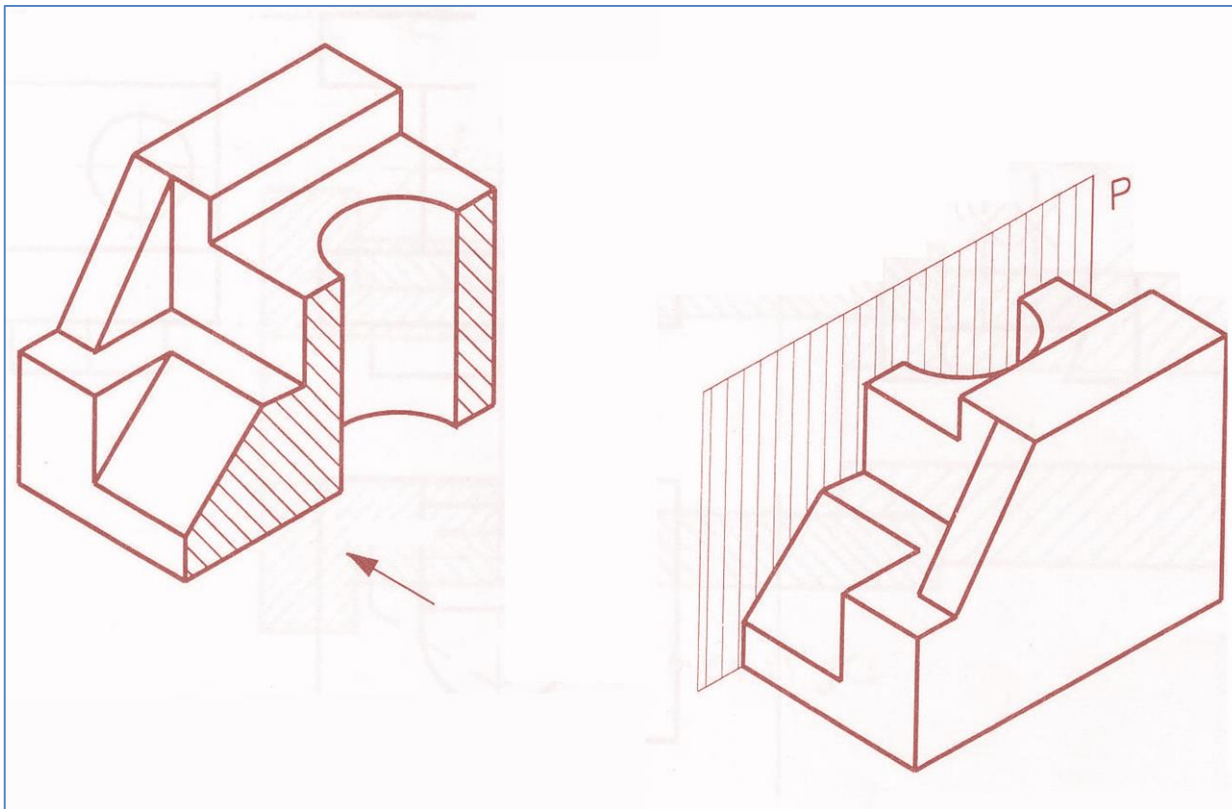

برش ساده

صفحه برش به موازات یکی از صفحات تصویر می باشد.

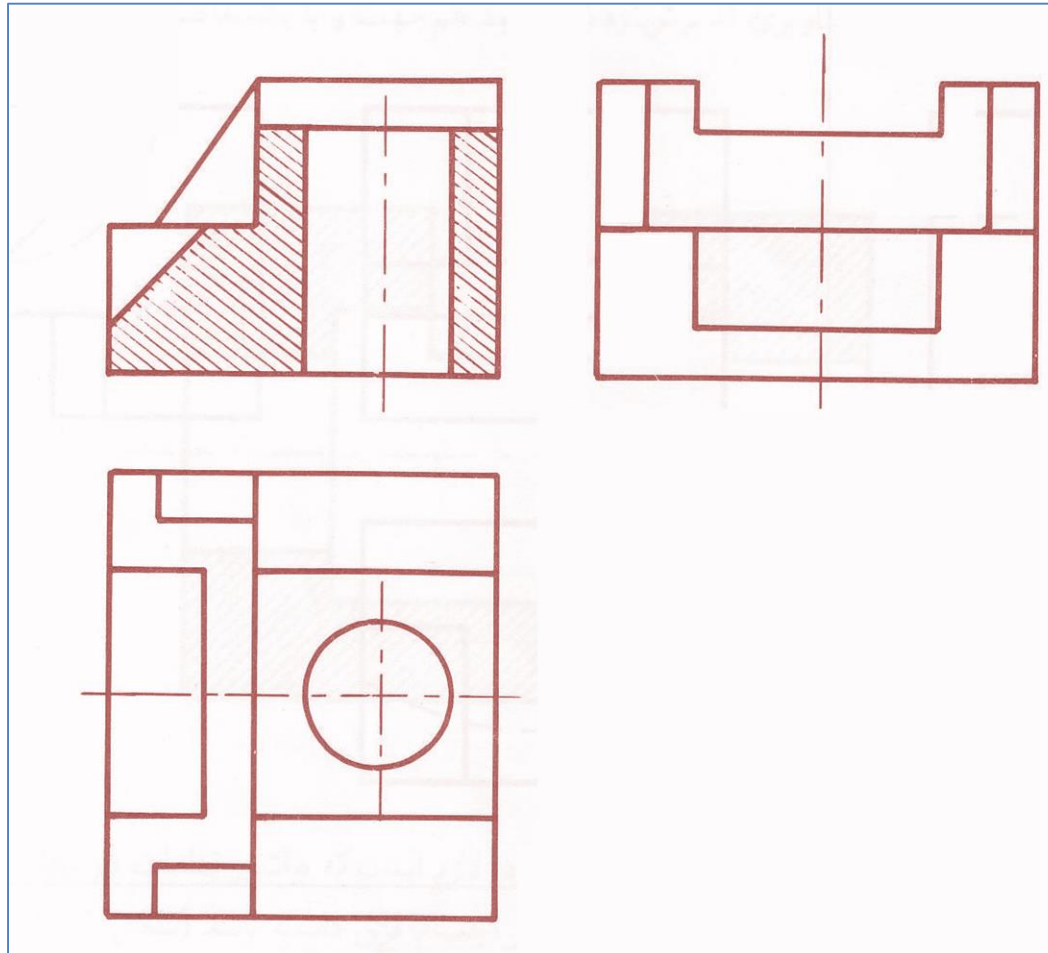

برش متقارن

صفحه برش صفحه تقارن جسم است.

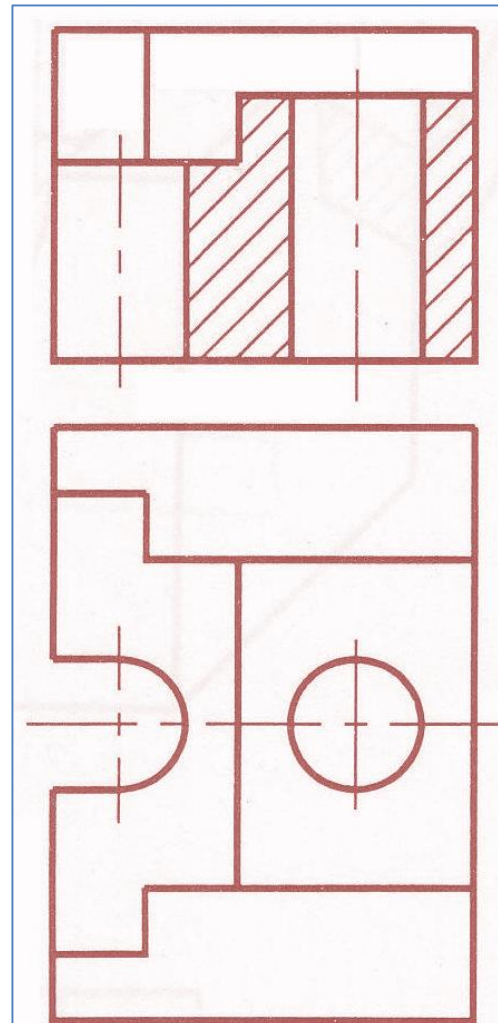
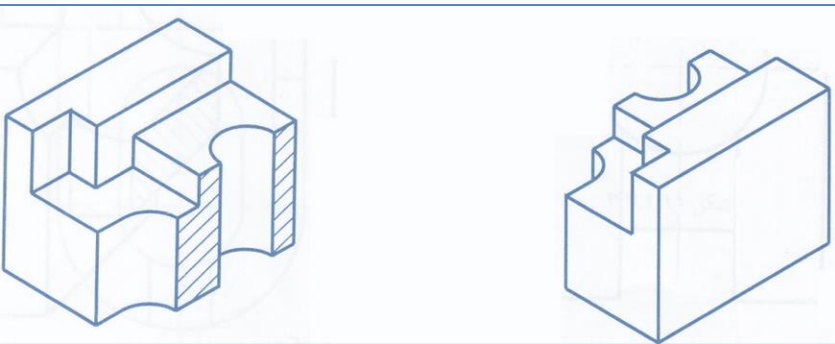
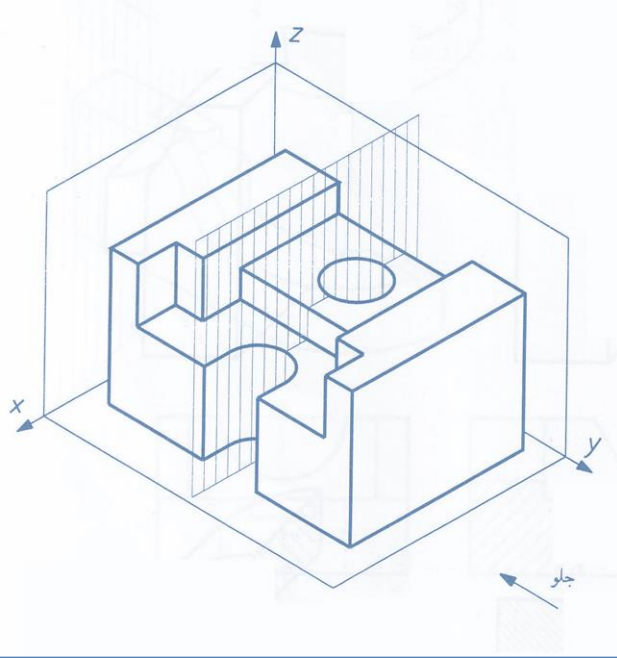

برش متقارن

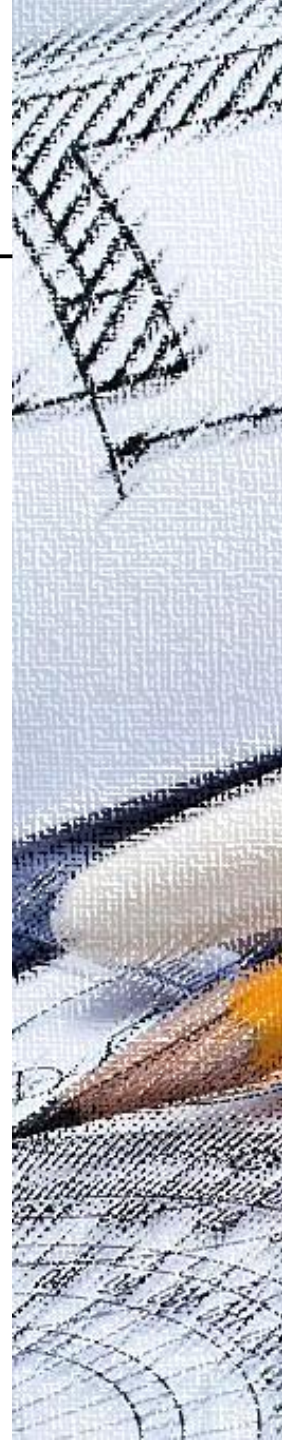
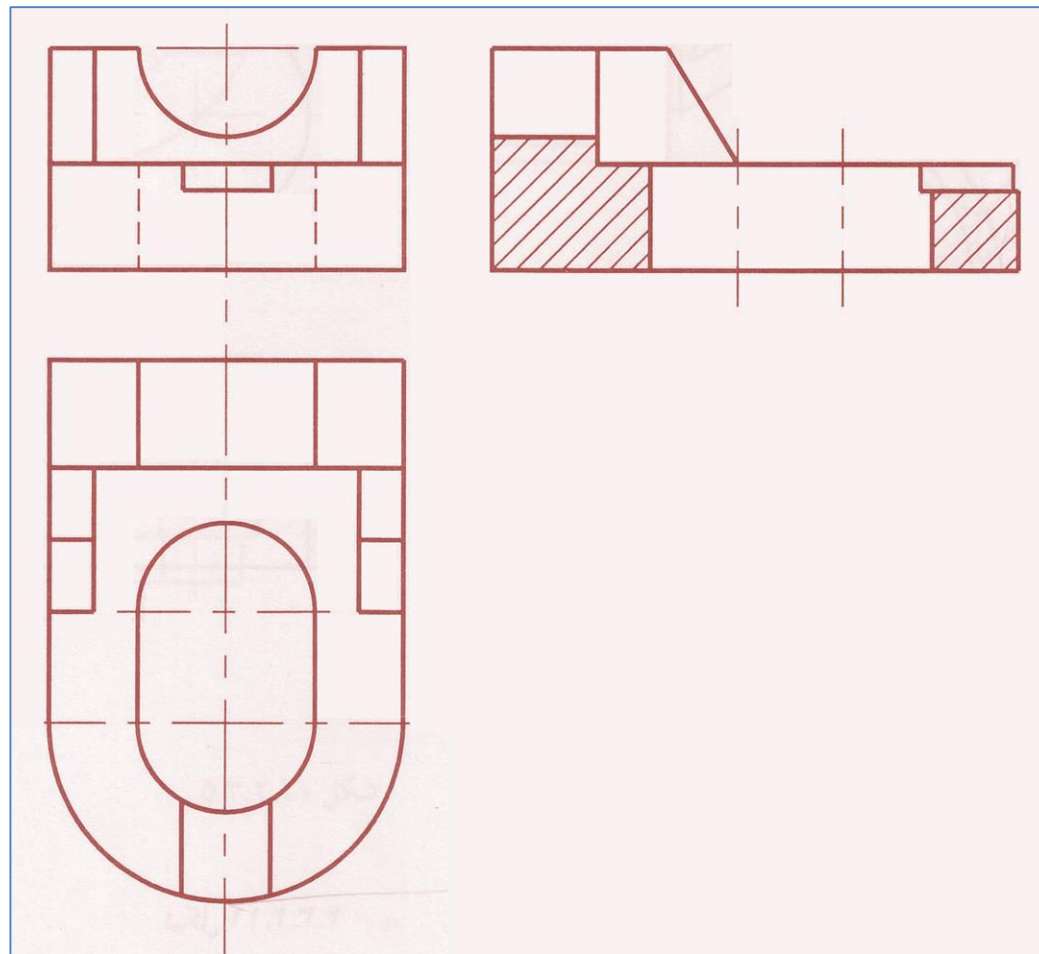
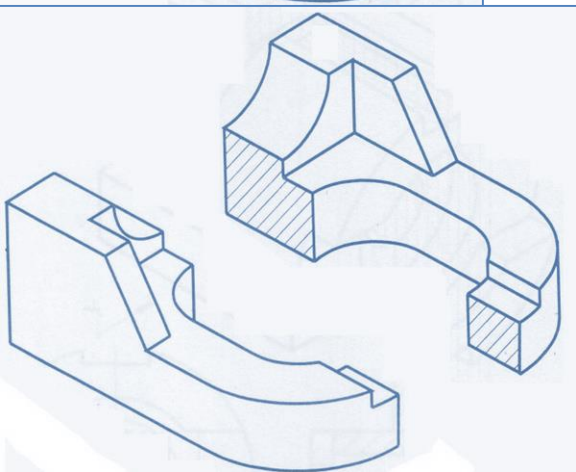
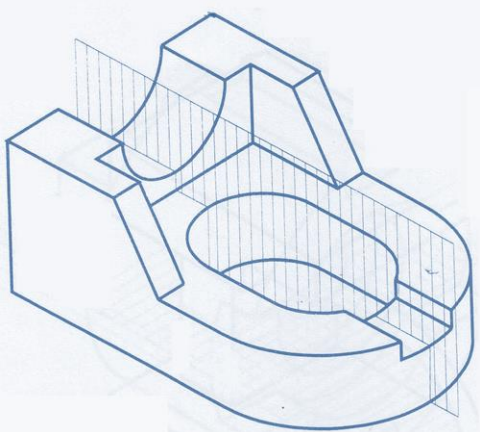

مثال: رسم برش متقارن

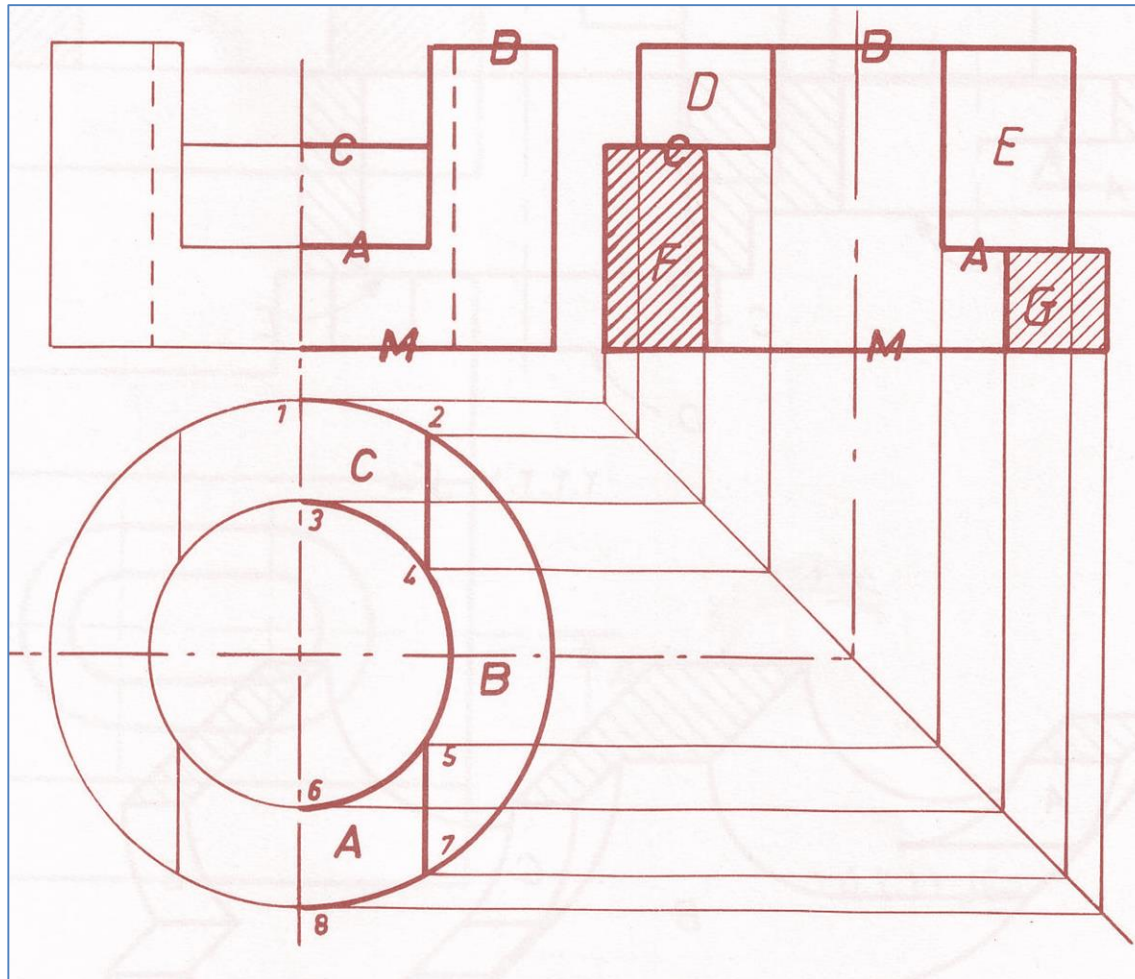

مثال: رسم برش متقارن

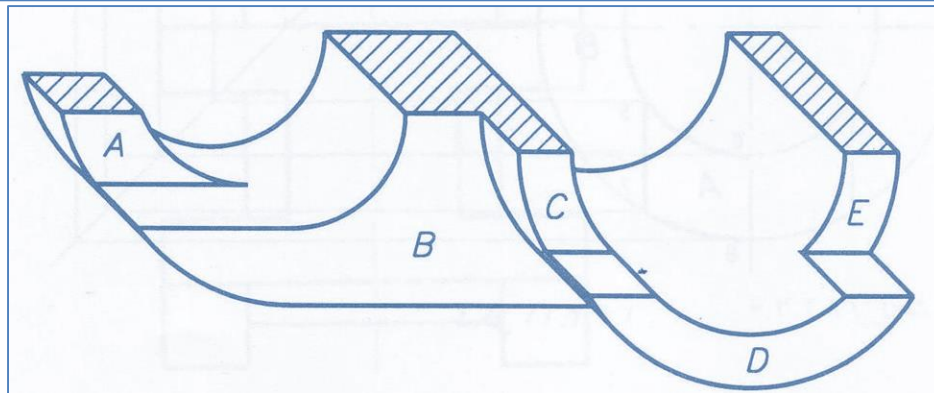
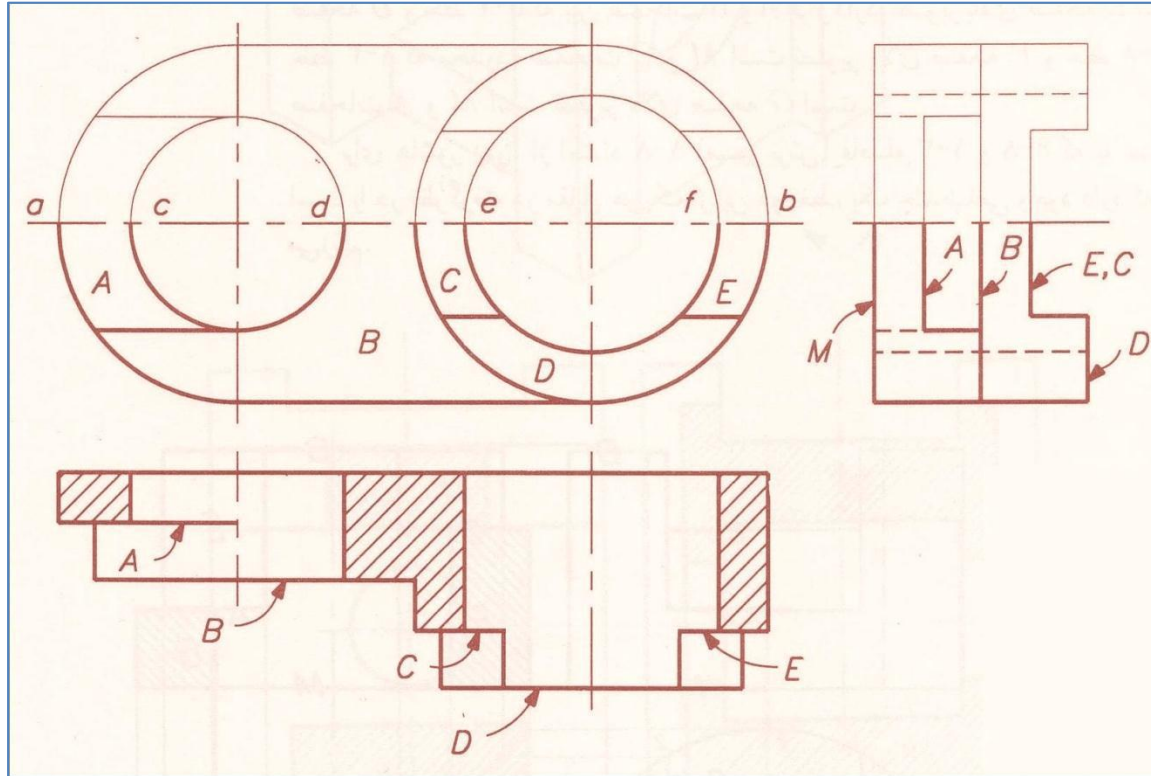

صفحه برش صفحه تقارن جسم نیست !!!

برش نامتقارن

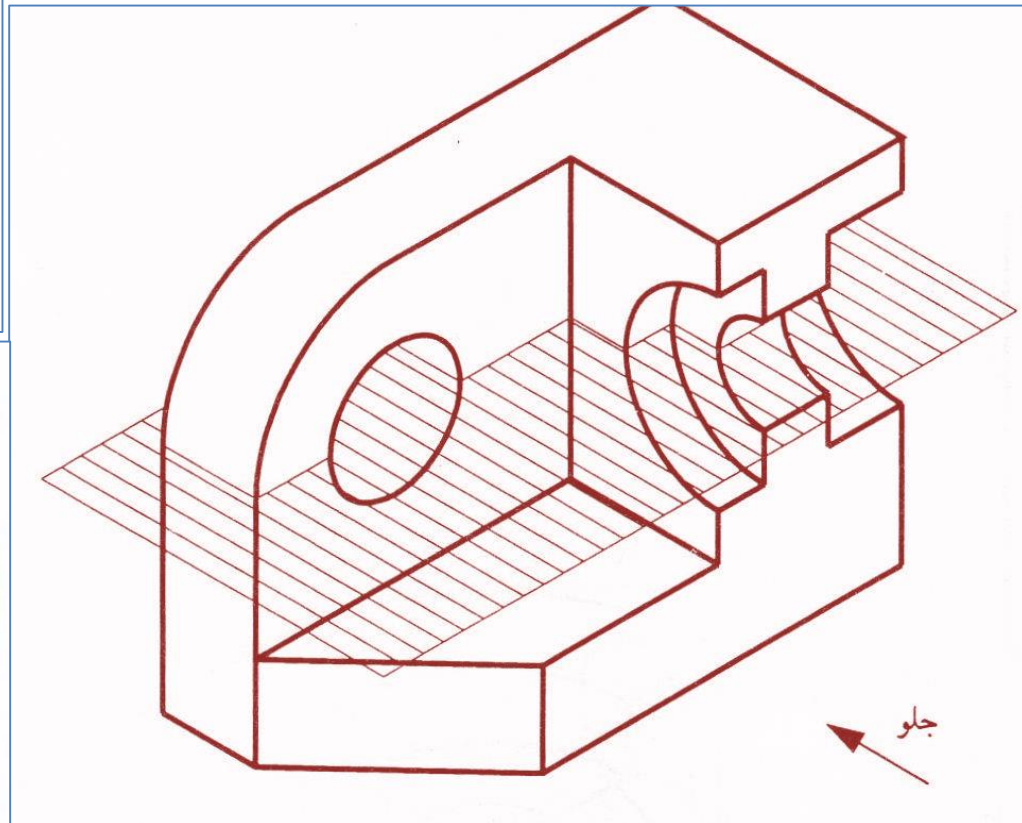
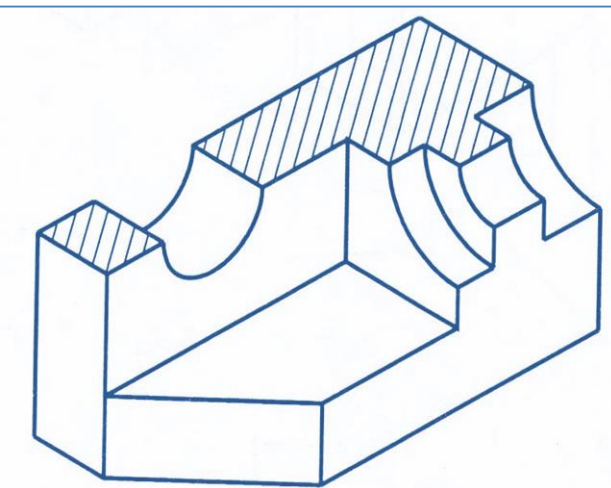
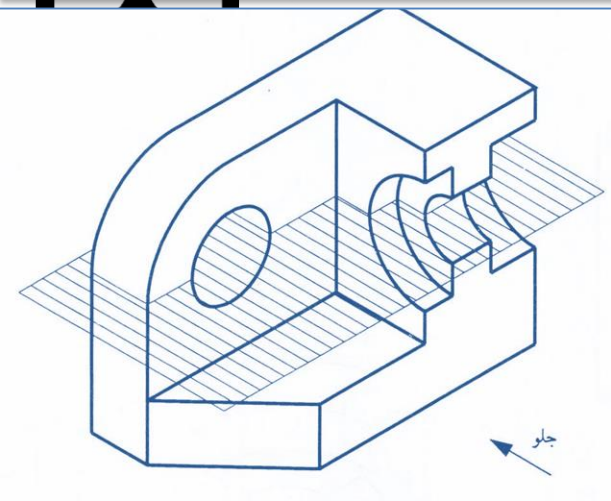



برش نامتقارن

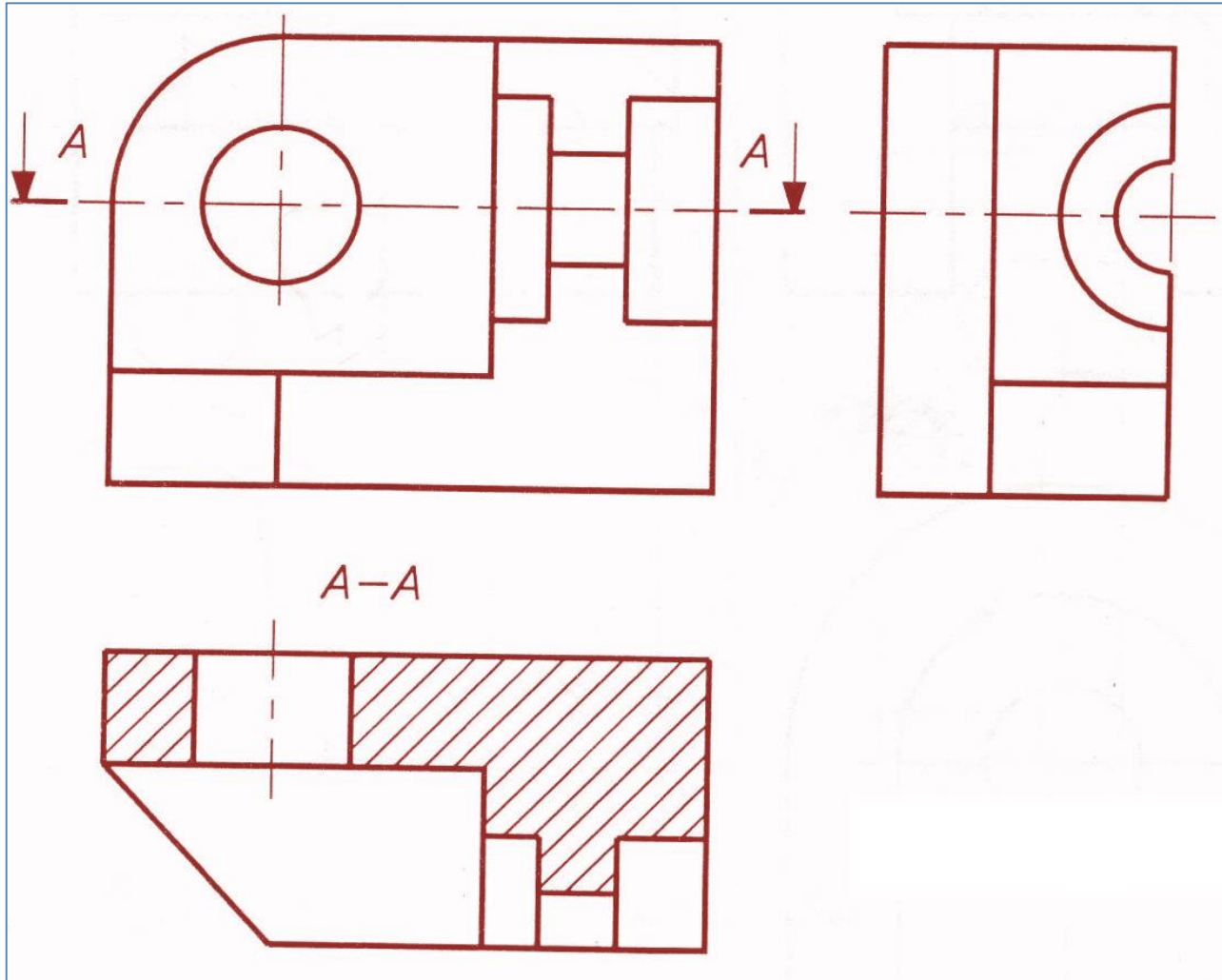

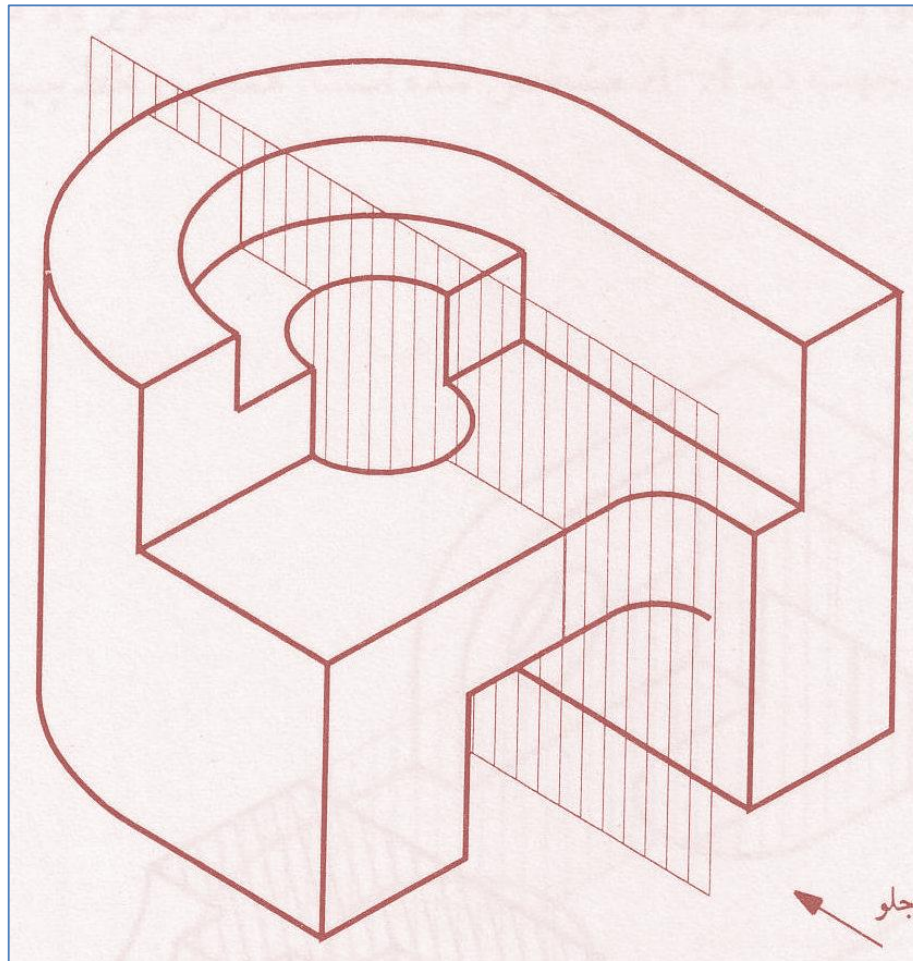
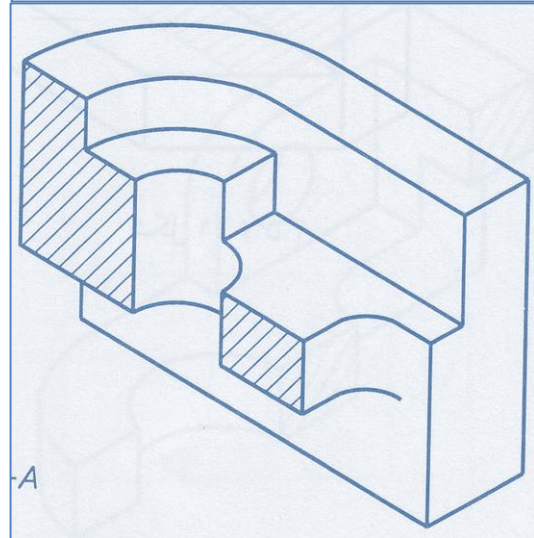
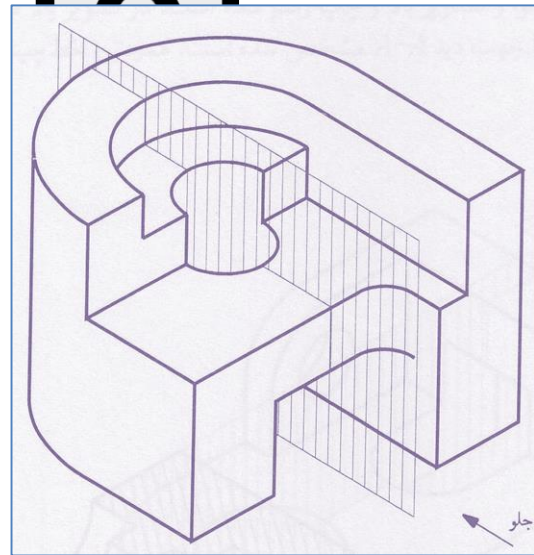



برش نامتقارن

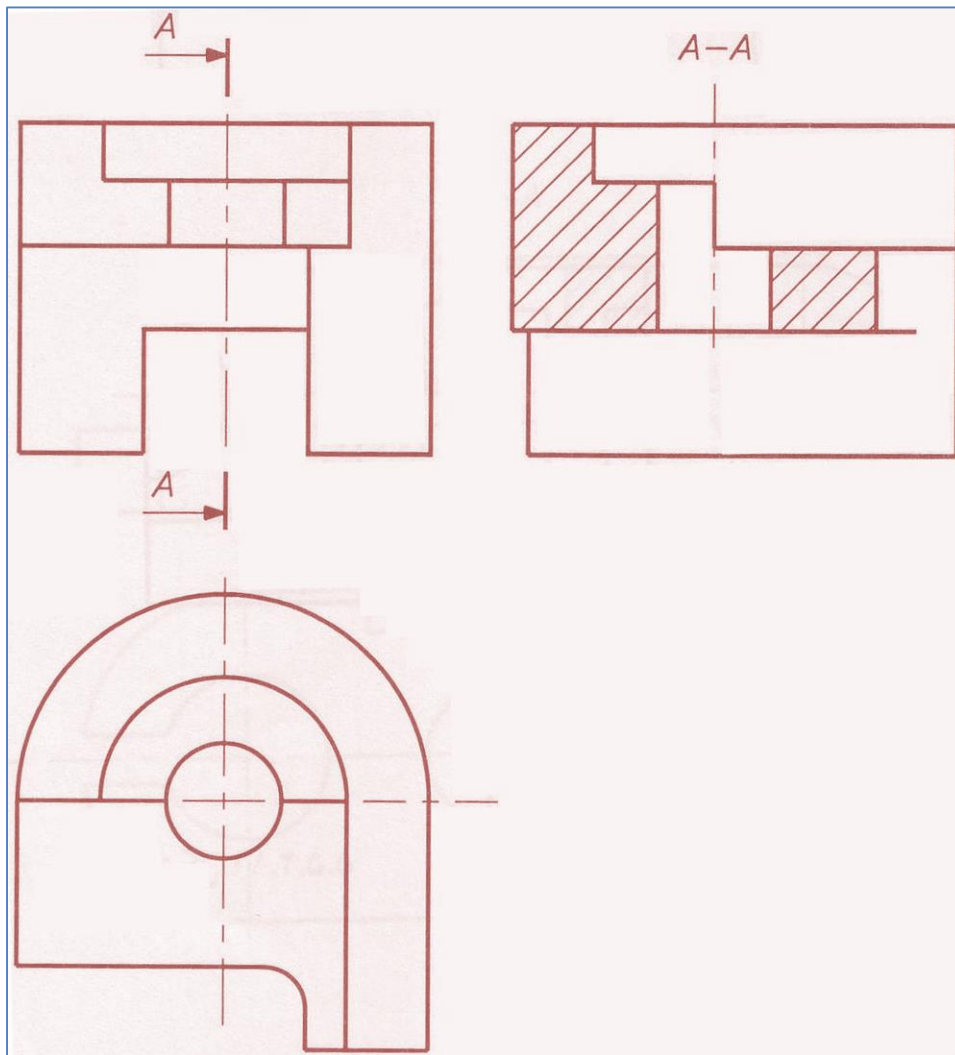

صفحه برش صفحه تقارن جسم نیست !!!

برش نامتقارن

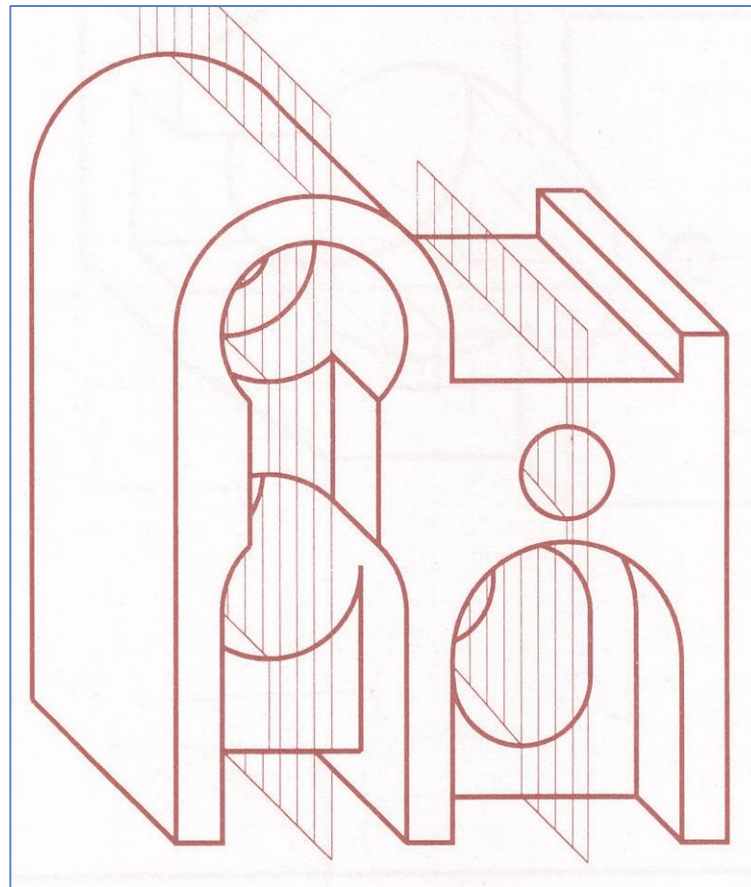
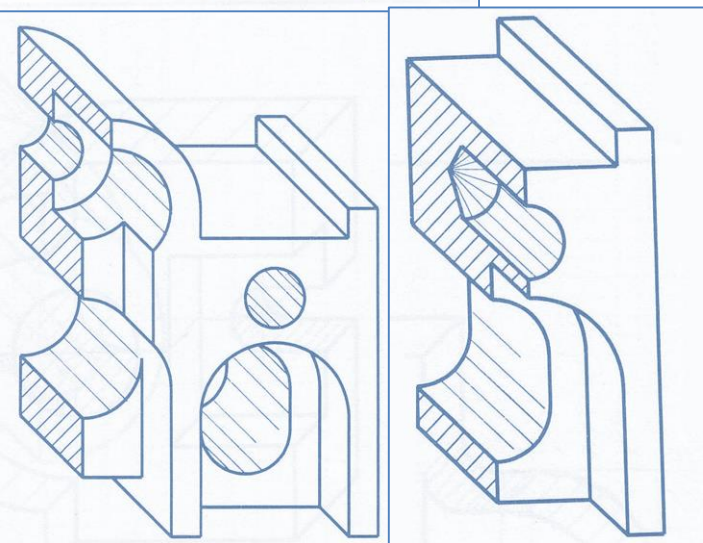
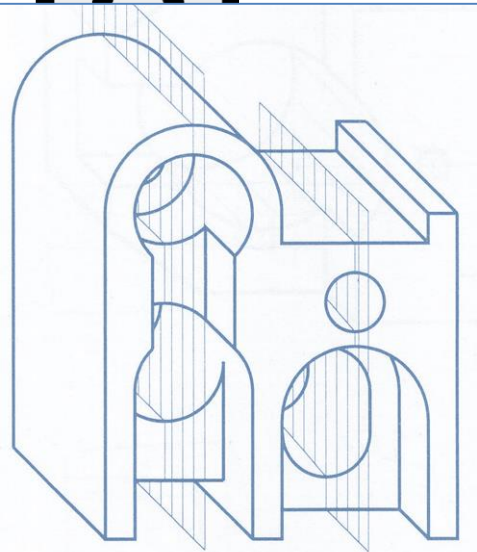



برش نامتقارن

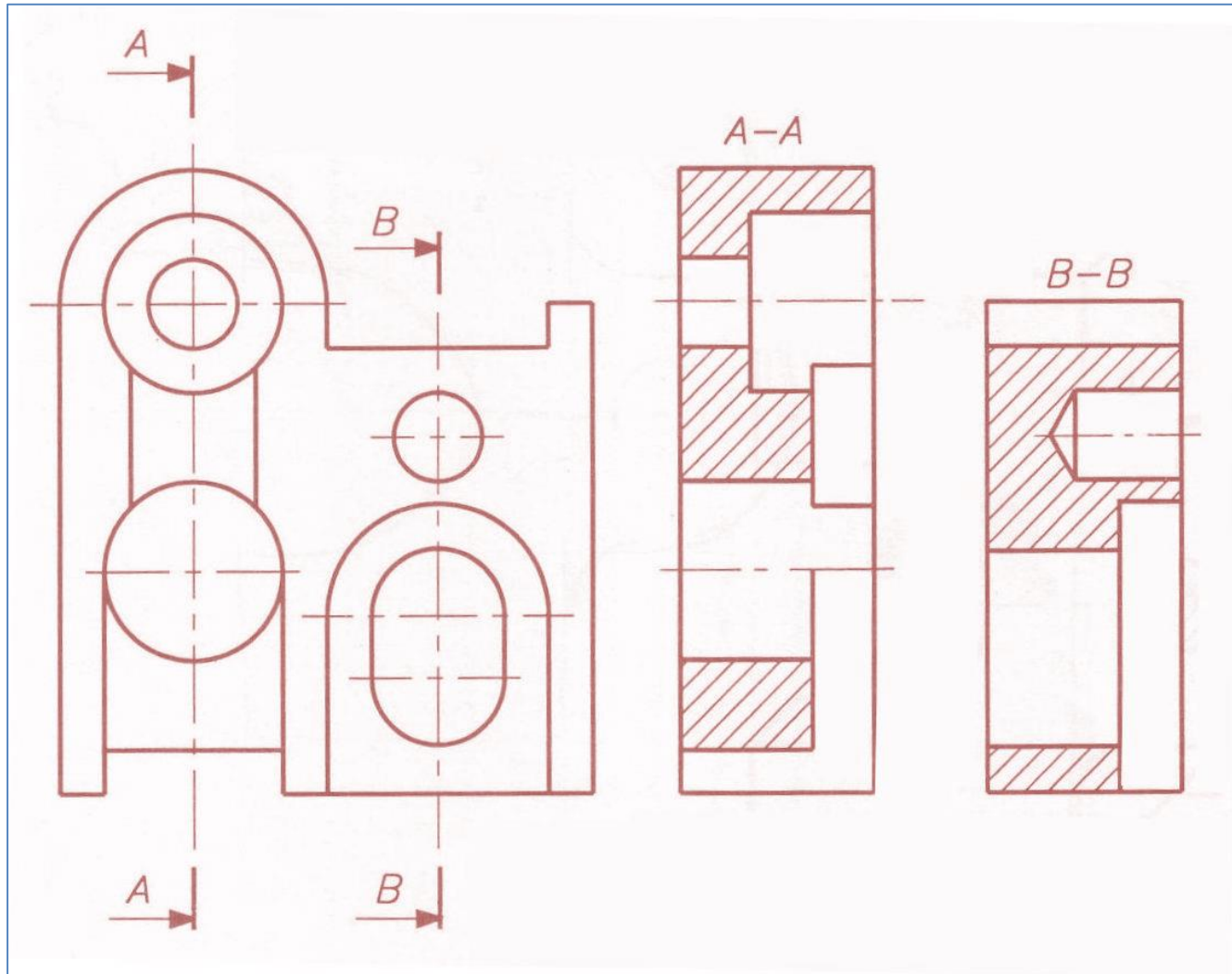



هاشور (Hatch)

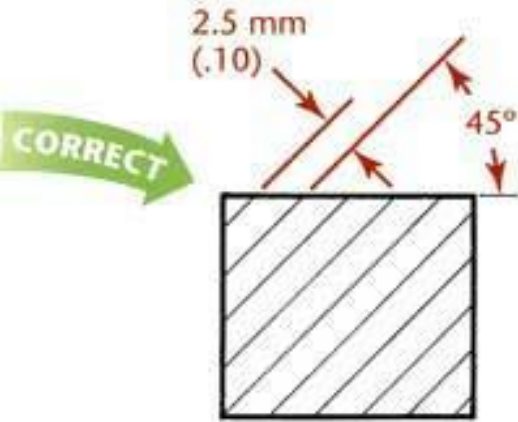

- Uniformly spaced by an interval of about 2.5mm
- Not too close together
- Uniformly thin, not varying in thickness
- Distinctly thinner than visible lines
- Do not run beyond or stop short of visible outlines

(a) Correctly drawn section lines





هاشور (Hatch)



(b) Direction of Section Lines

If section lines drawn at 45° with horizontal would be parallel or perpendicular (or nearly so) to a prominent visible outline, the angle should be changed to 30° , 60° , or some other angle.

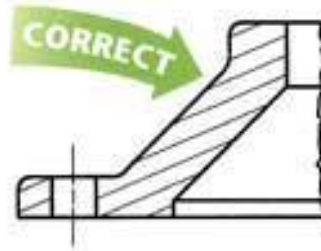

Angle of section lines is adjusted



Lines should not be parallel to outline

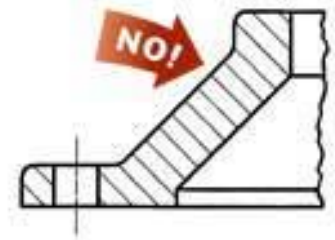

Lines should not be perpendicular to outline





هاشور (Hatch)

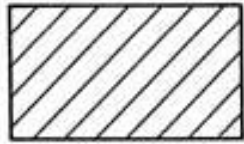

1

Cast or malleable iron and general use for all materials



6

Rubber, plastic, and electrical insulation



11

Electric windings, electromagnets, resistances, etc.

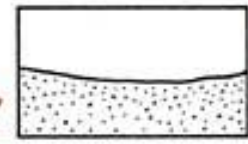

16

Sand



2

Steel



7

Cork, felt, fabric, leather, and fiber

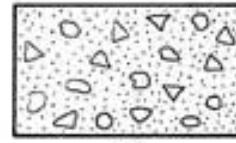

12

Concrete



17

Water and other liquids

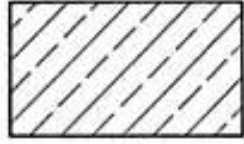

3

Bronze, brass, copper and compositions



8

Sound insulation

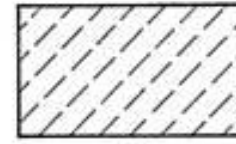

13

Marble, slate, glass, porcelain

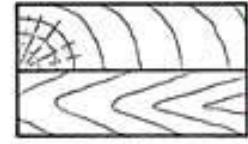

18

Across grain
WOOD
With grain

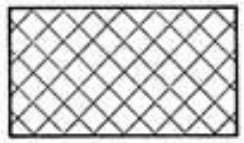

4

White metal, zinc, lead, babbitt, and alloys



9

Thermal insulation

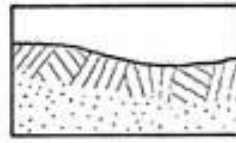

14



5

Magnesium, aluminum, and aluminum alloys



10

Titanium and refractory material

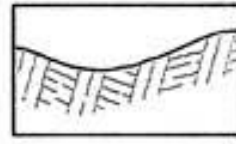

15



برش شکسته ساده

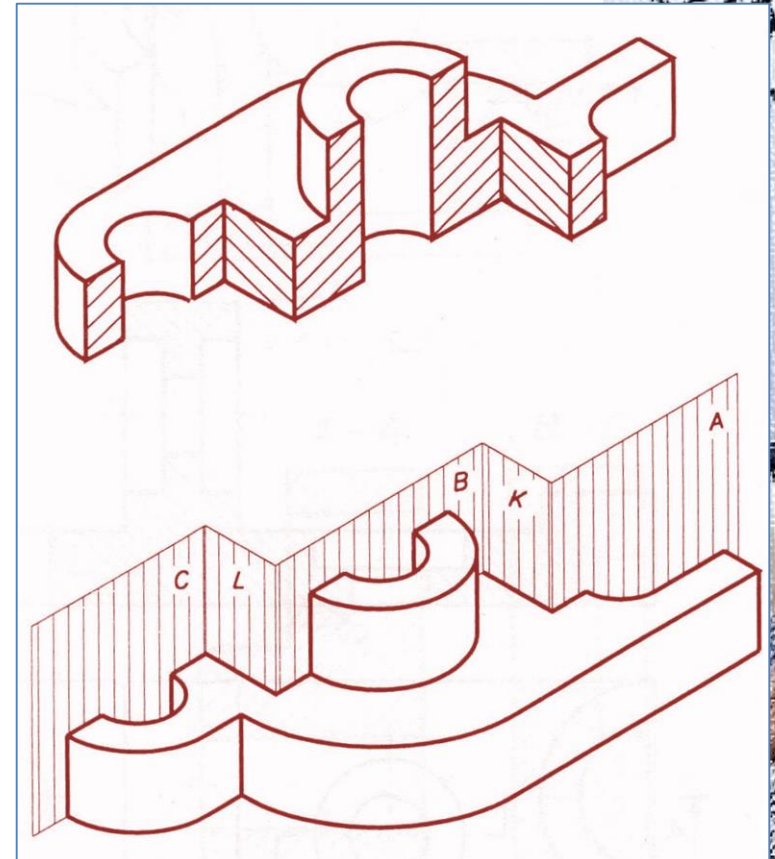
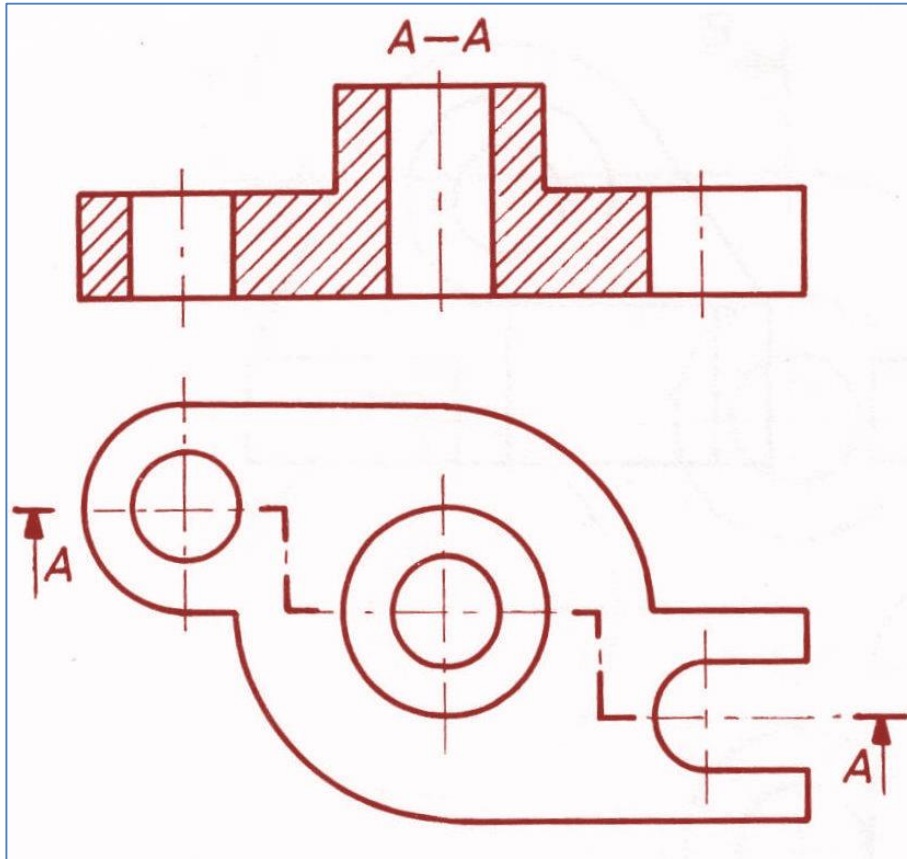



نگاه سنان

برش شکسته ساده

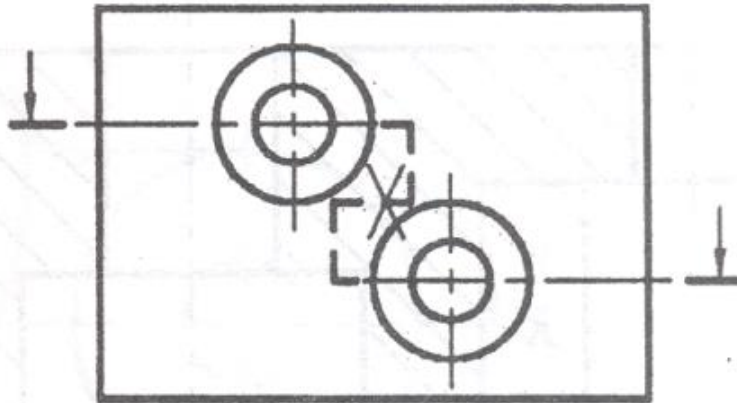
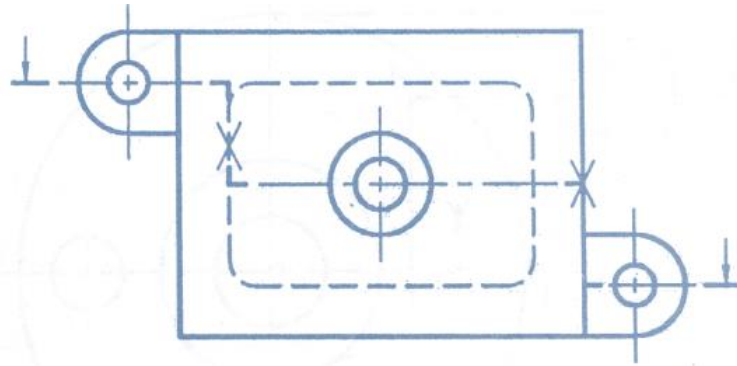
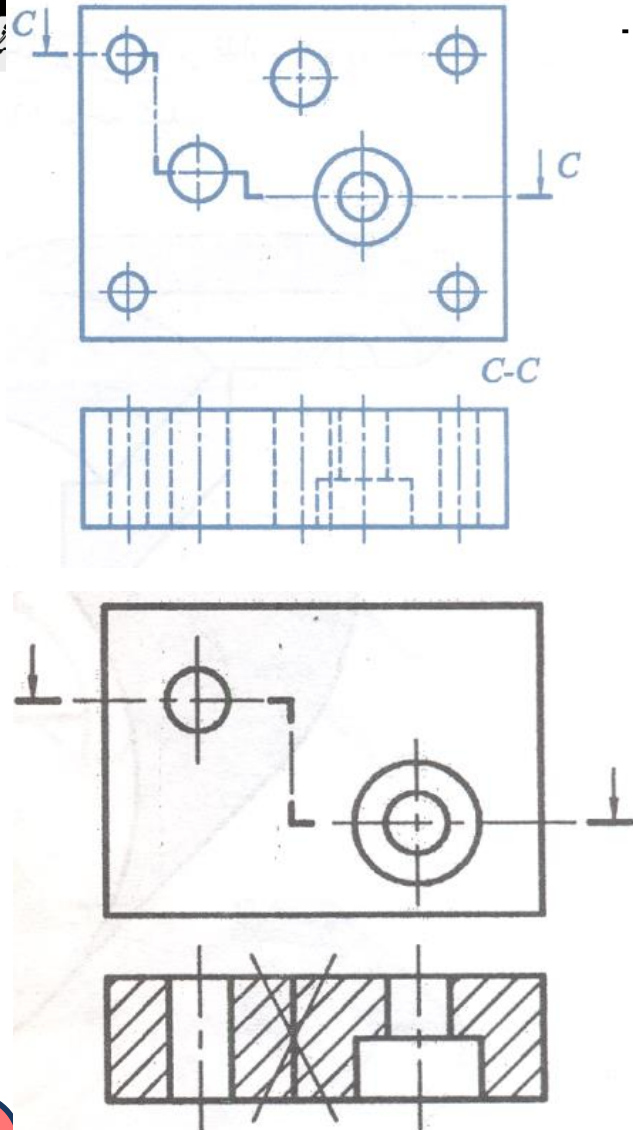

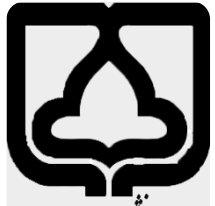

برش شکسته ساده

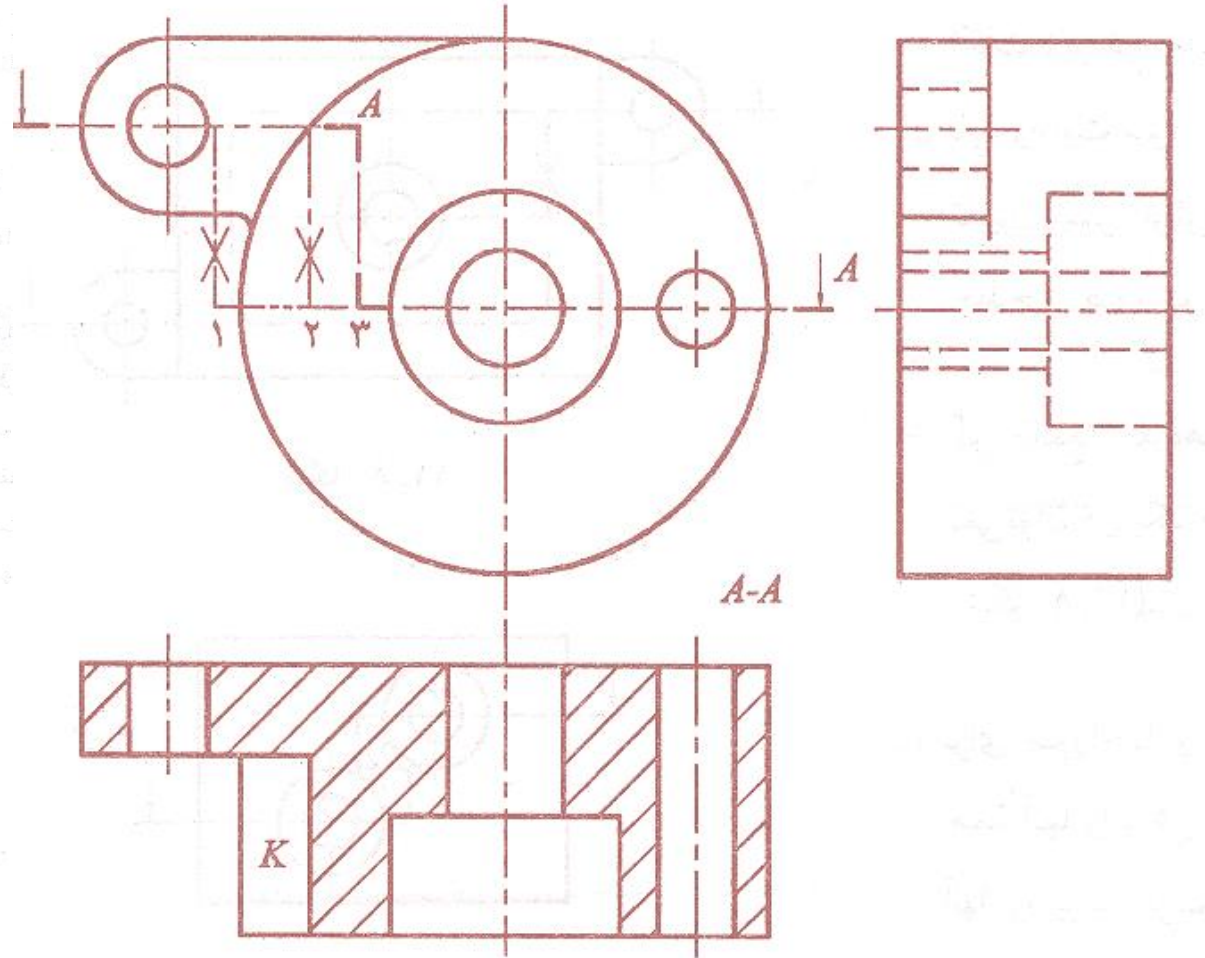
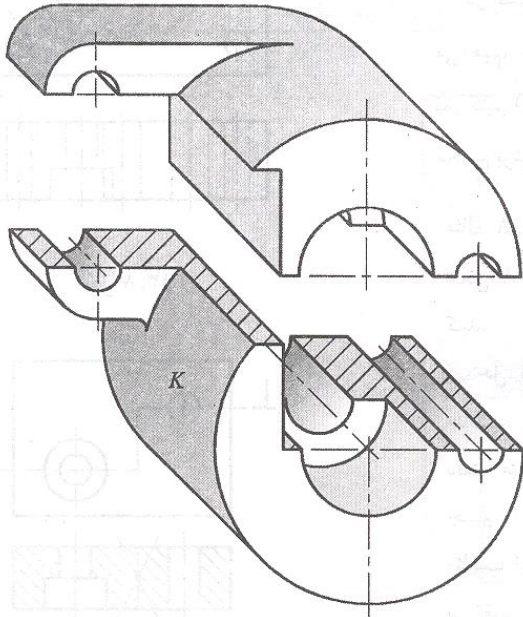

برش شکسته ساده

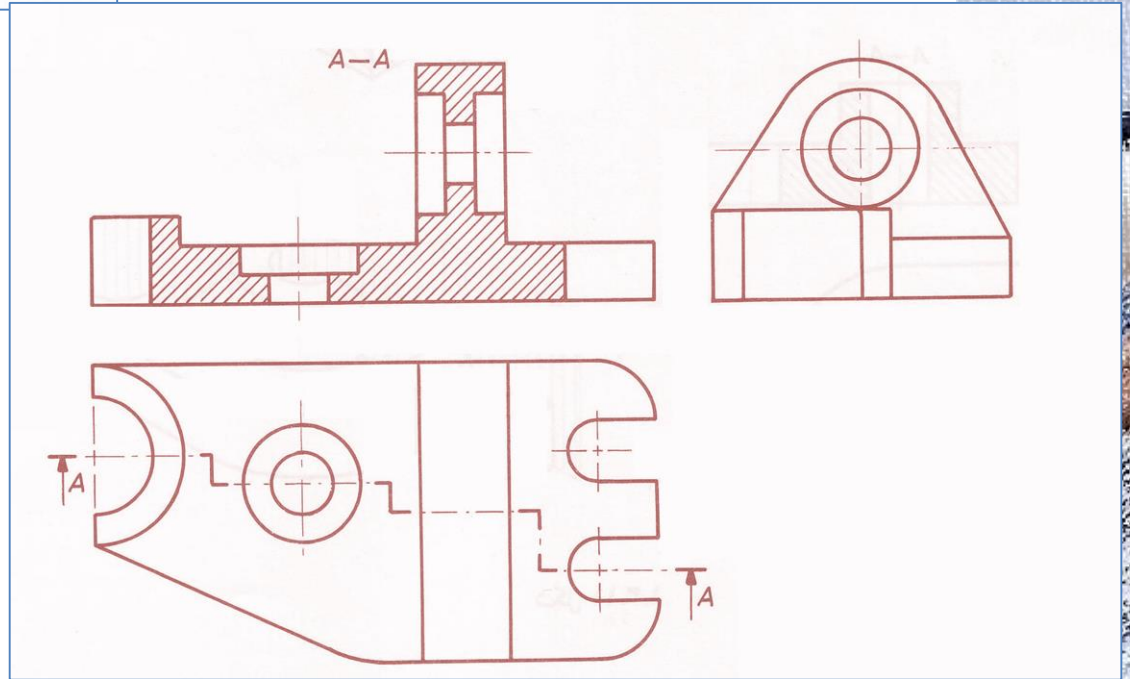
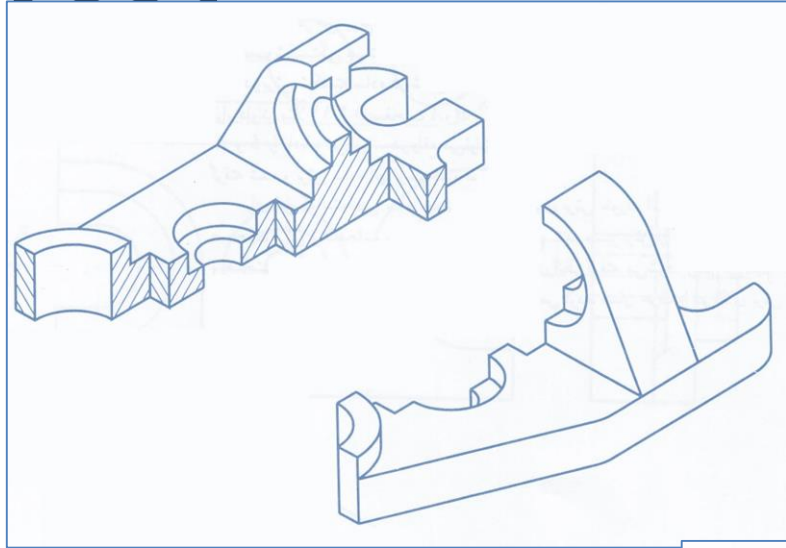



برش شعاعی

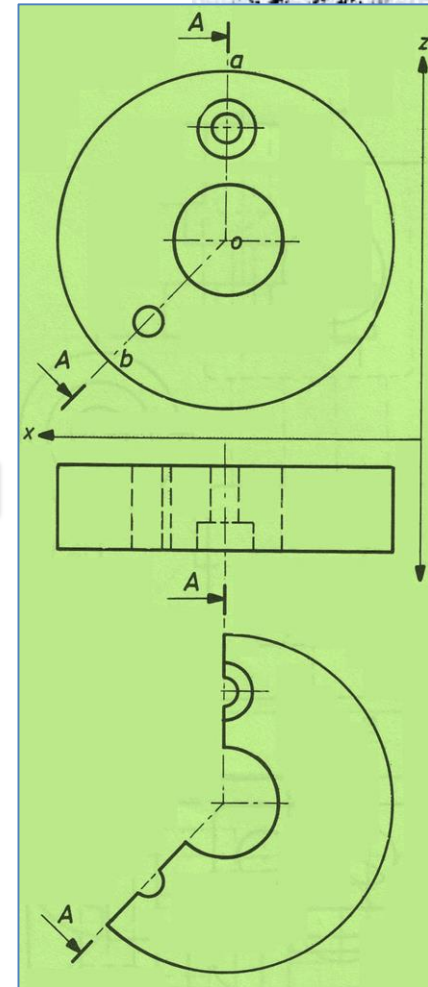
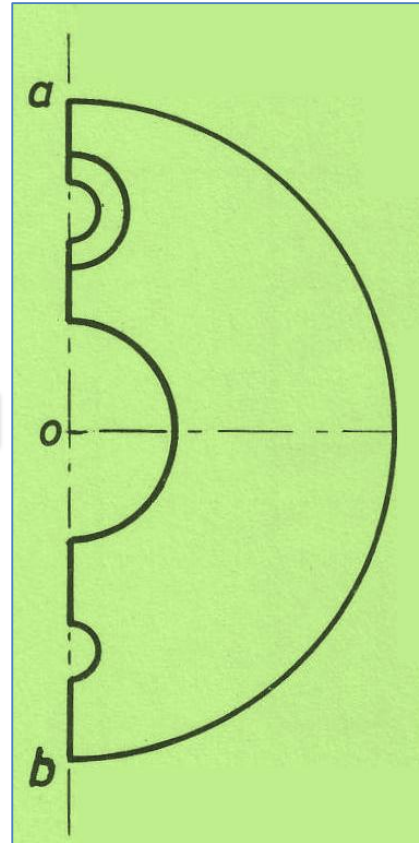
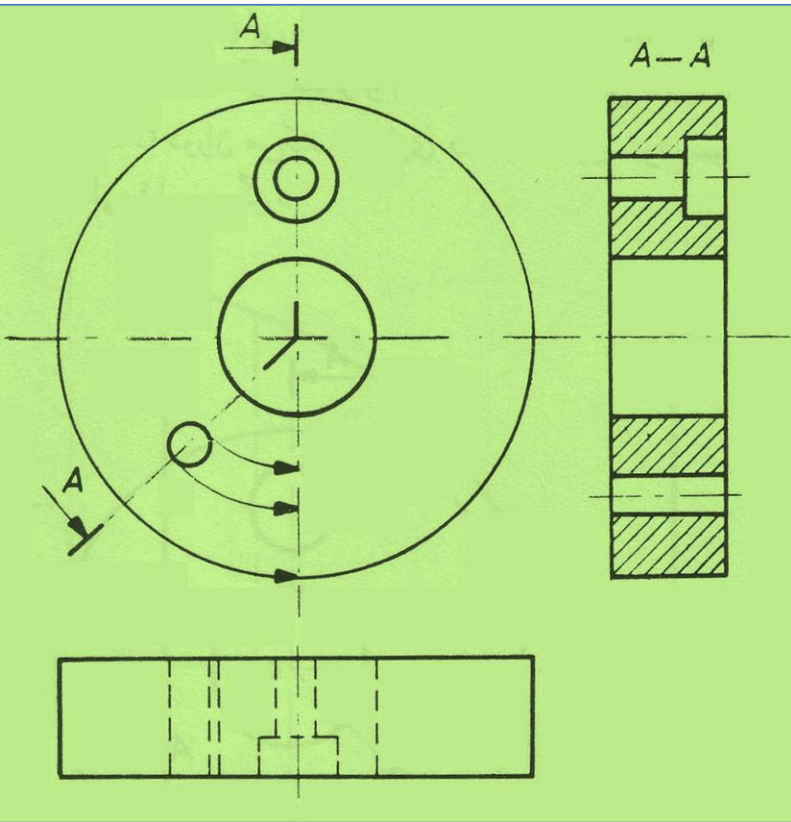

برش شعاعی

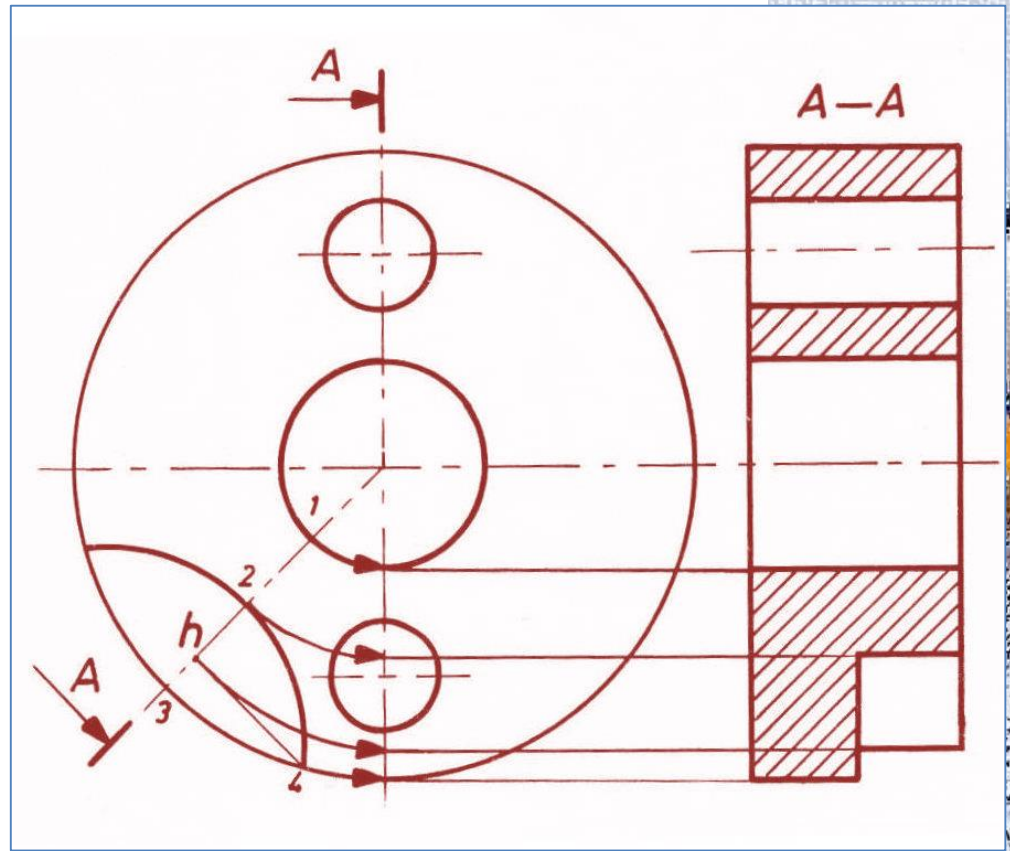
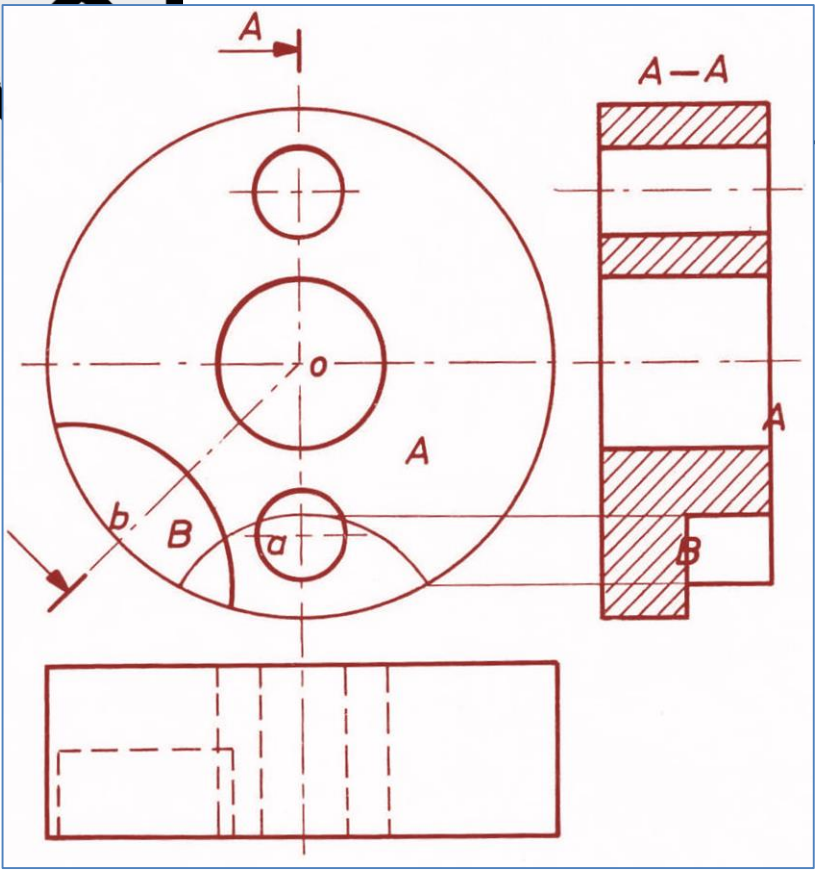

برش شکسته

شکسته

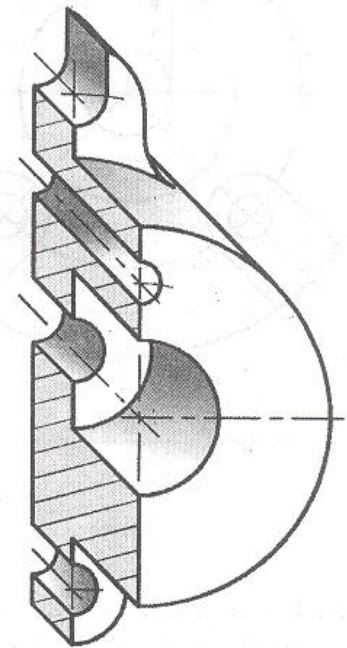
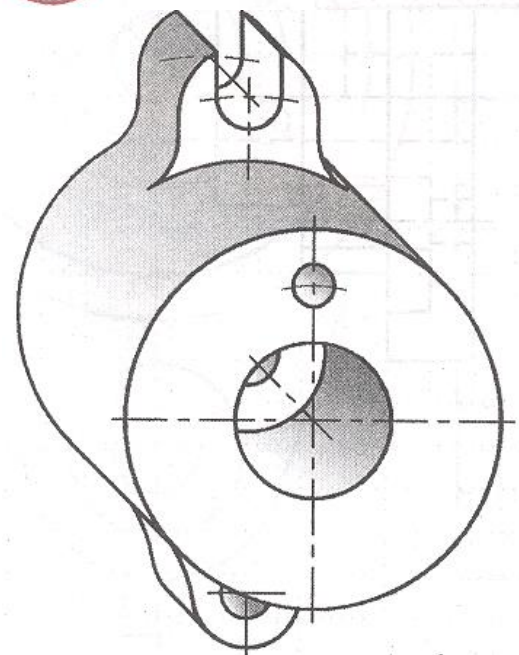
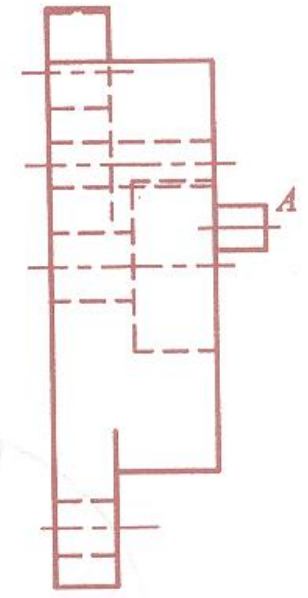
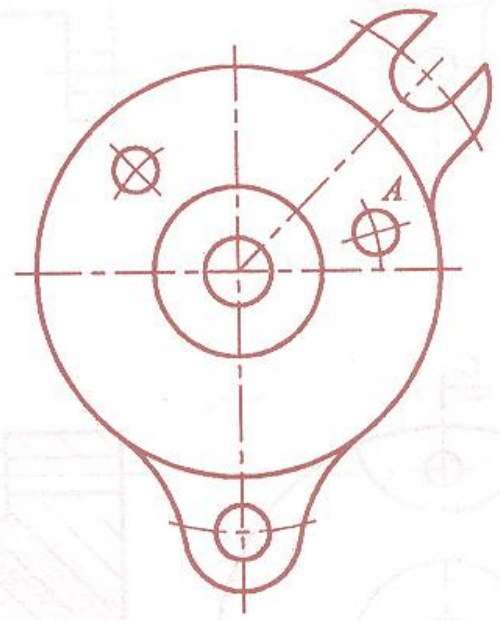
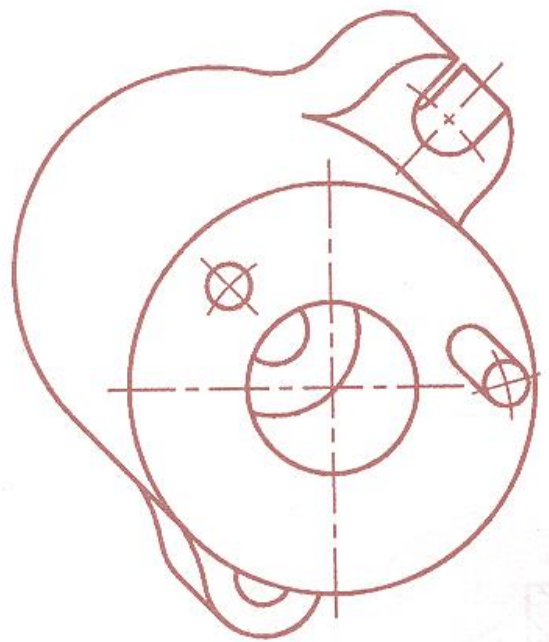



برش شکسته شعاعی

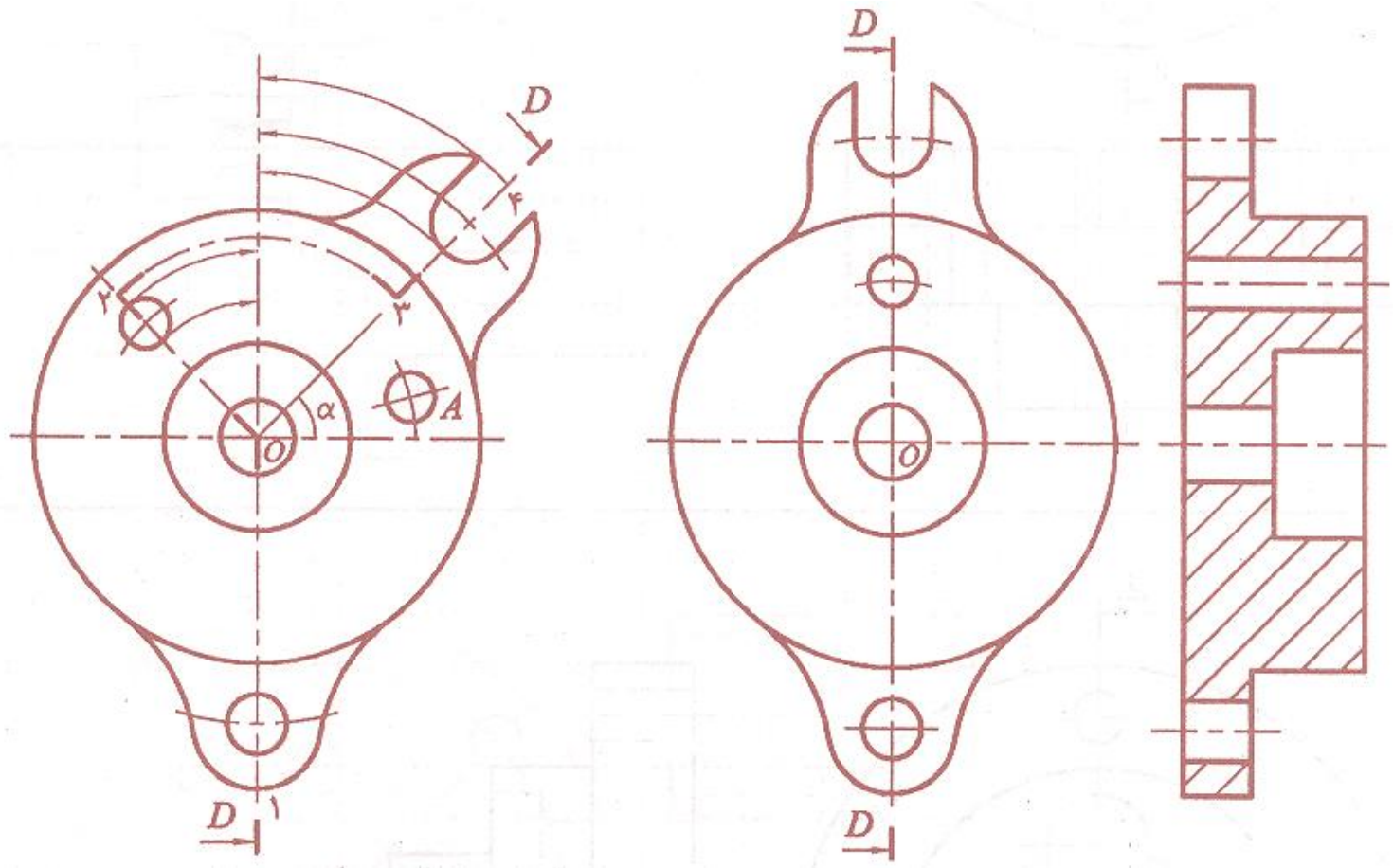

برش شکسته مایل

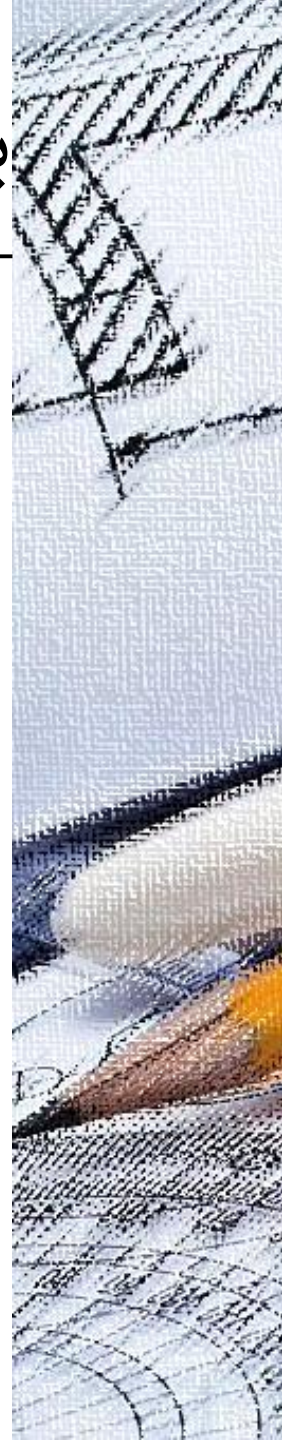
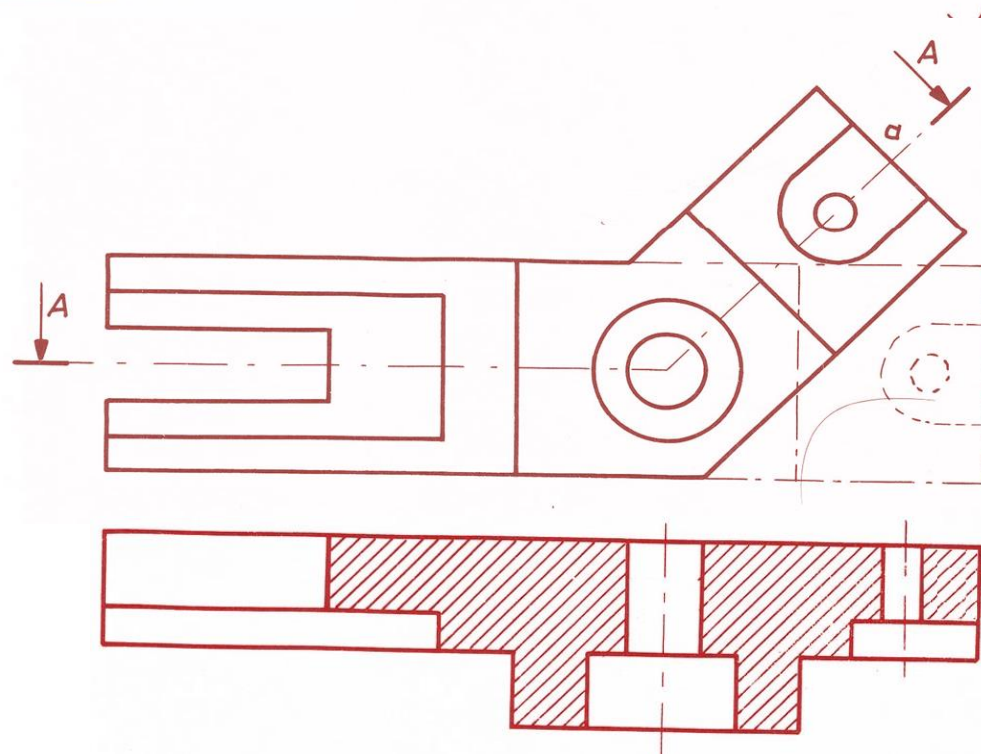
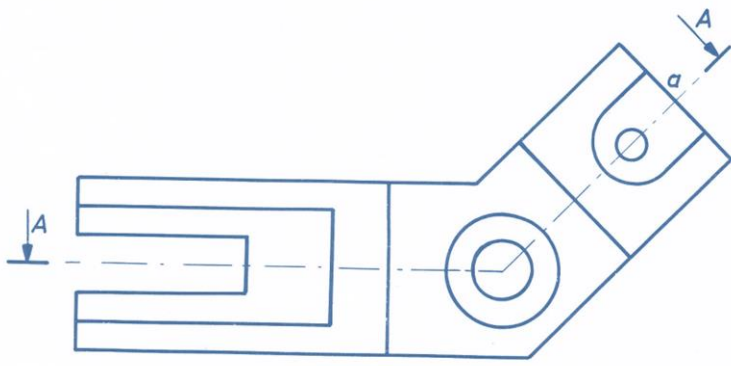

نیم برش

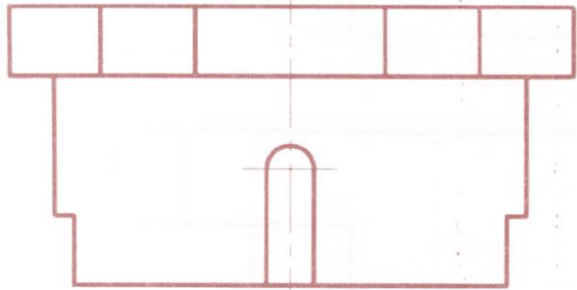
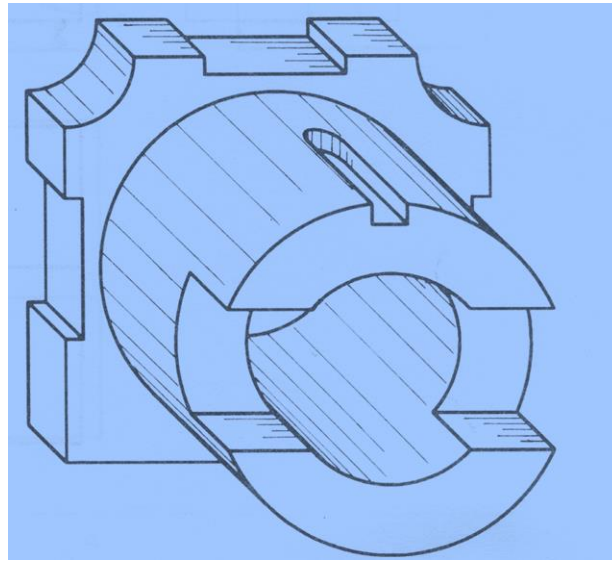
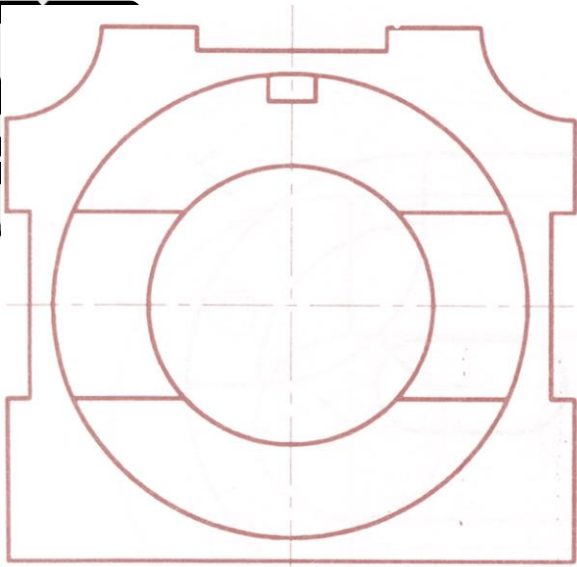

A-A

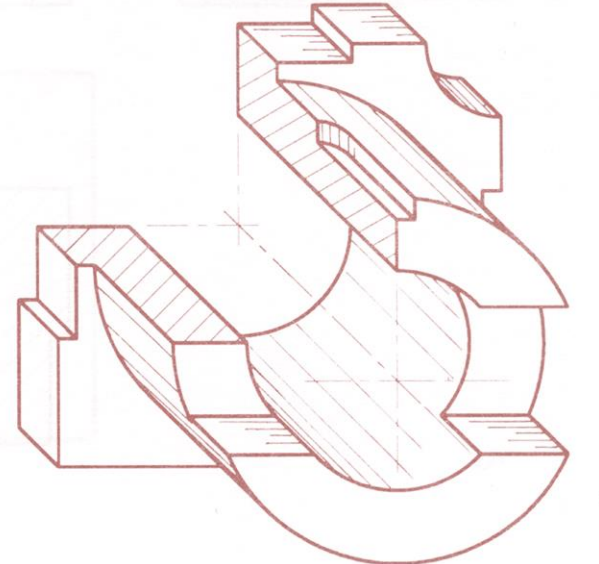
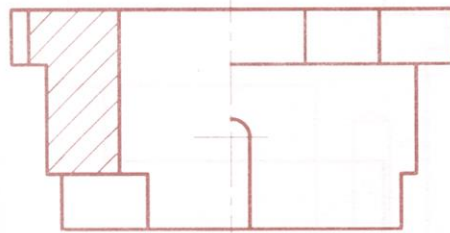
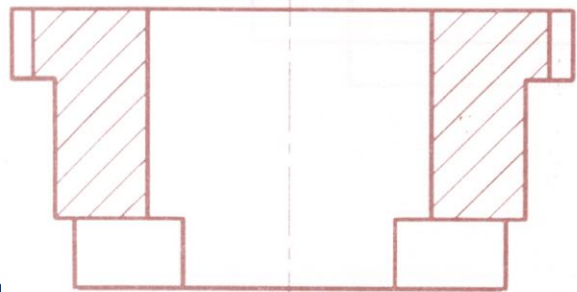



نیم برش

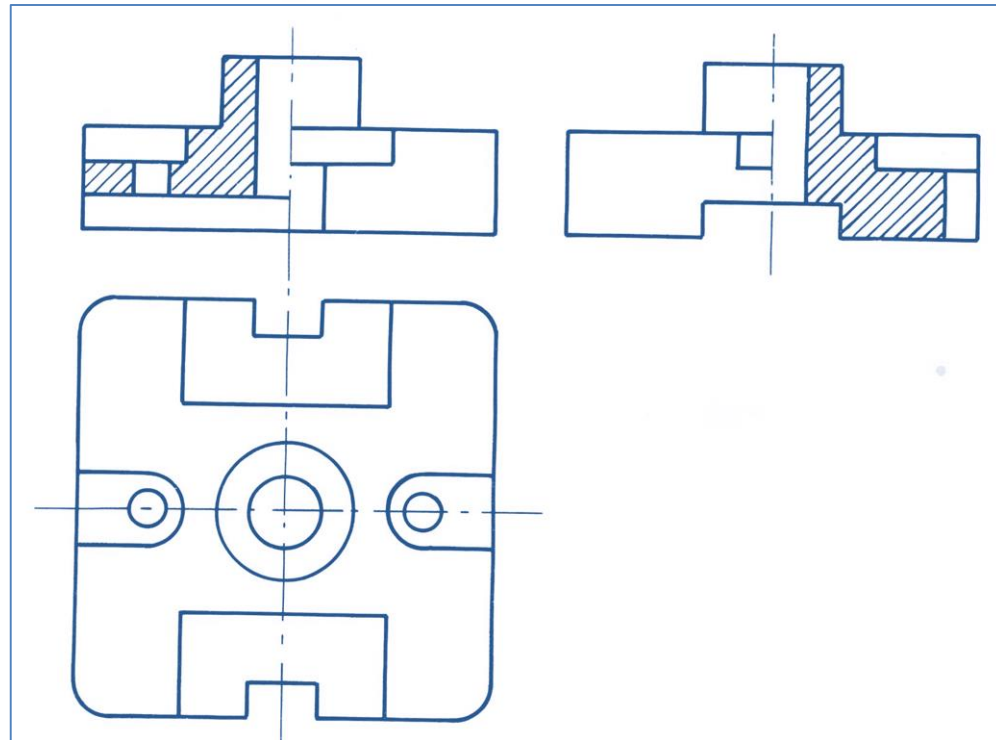
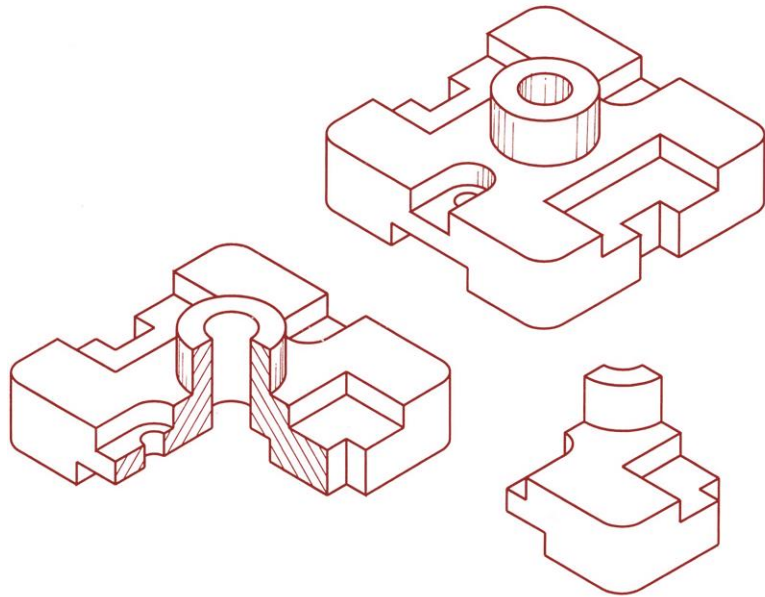

نیم برش شکسته

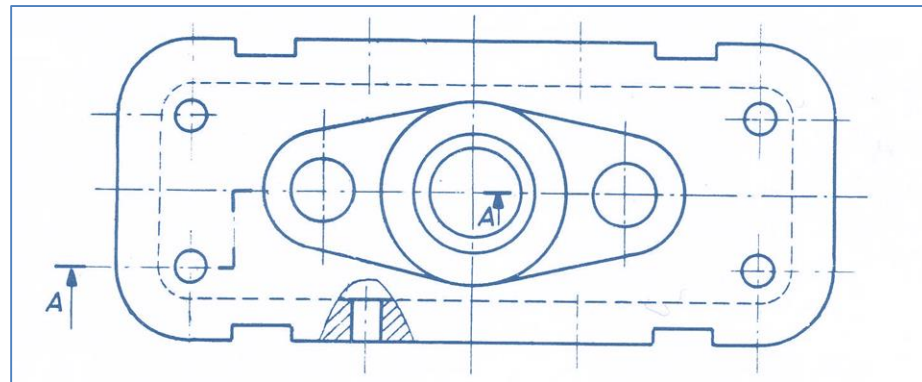
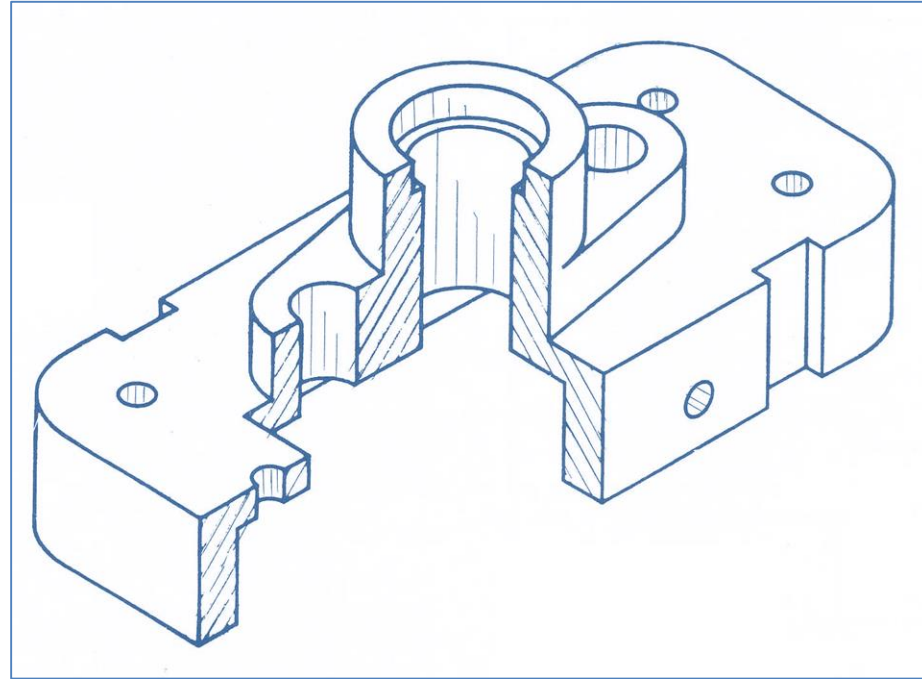
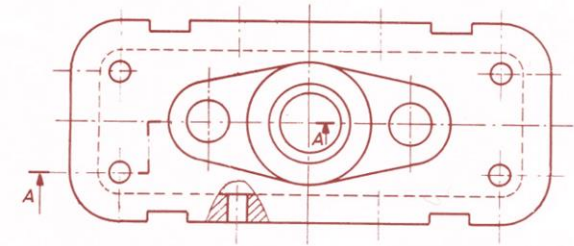
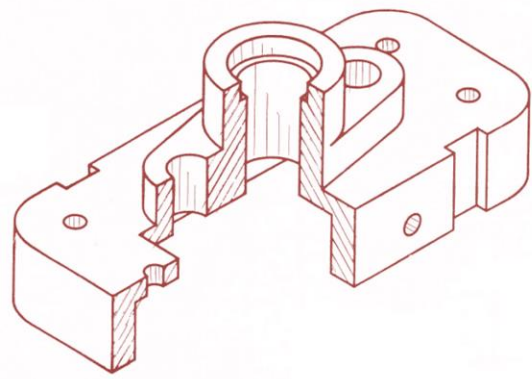

نیم برش شکسته

